

# Universal Steam traps

For an extensive range of applications



**Pressure rating: up to 4000 psig**  
**NPS 3/8-3 (DN 10-80)**

**VELAN**

# VELAN COMPANY PROFILE

## VELAN AT A GLANCE

### History

- Founded in 1950

### Sales

- Over \$500 million

### People

- Over 2,000 employees

### Product line

A world-leading range of valves across all major industrial applications:

- Cast steel gate, globe, check, and ball valves
- Forged steel gate, globe, check, and ball valves
- Triple-offset butterfly valves
- Knife gate valves
- Severe service valves
- Bellows seal valves
- Steam traps

### Quality

All major certifications and approvals

- ASME N stamp and NPT for nuclear valves (since 1970)
- ISO 9001 (since 1991)  
Currently certified to ISO 9001:2008
- PED
- GOST (TR and RTN)
- API 6A and API 6D
- TA-Luft
- Quality programs fully compliant with ISO-9001, NCA 4000, ASME NQA-1 and 10 CFR 50 Appendix B, surveyed by ASME and audited by NUPIC, Northrop Grumman Newport News, DCMA, utilities, architect/ engineers, and other organizations from around the world

Headquartered in Montreal, Velan has several international subsidiaries.

For general inquiries:

Velan head office:  
7007 Côte de Liesse,  
Montreal, QC H4T 1G2 Canada

Tel: +1 514 748 7743  
Fax: +1 514 748 8635

Check our website for more specific contact information.

[www.velan.com](http://www.velan.com)



Velan is one of the world's leading manufacturers of cast and forged steel gate, globe, check, ball, triple-offset, knife gate, highly engineered severe service valves, and steam traps offering superior performance across all major industrial applications including: fossil, nuclear, and cogeneration power; oil and gas; refining and petrochemicals; chemicals and pharmaceutical; LNG and cryogenics; marine; HVAC; mining; water and wastewater; pulp and paper; and subsea. The company also supplies actuators and integrated control packages.

Founded in 1950, Velan has earned a reputation for product excellence and innovation by bringing to the market superior products with special emphasis on quality, safety, ease of operation, and long service life. Velan valves have an extremely broad installation base and are approved by major companies worldwide.

Velan concentrates on one business—the design, manufacture and marketing of steel valves in a broad range of types and sizes for high performance service in a wide range of applications. The company's talented people are focused on Velan's core values of quality, reliability, innovation, and integrity and mission to be the world's leading valve brand.

For more specific information concerning steam traps:

Velan Valves Ltd.  
Unit 1, Pinfold Road, Thurmaston, Leicester, LE4 8AS England  
Tel: +44 116 269 5172 Fax: +44 116 269 3695 Email: [sales@velan.co.uk](mailto:sales@velan.co.uk)  
[www.velansteamtraps.com](http://www.velansteamtraps.com)

© 2014 Velan Inc., Montreal, QC, Canada. All rights reserved. The contents hereof are confidential and proprietary to Velan. Any unauthorized reproduction or disclosure, in whole or in part, is strictly prohibited. The material in this catalog is for general information only and shall not be used for specific performance data and material selection without first consulting Velan. Velan reserves the right to change this information without notice. Velan does not accept any liability or damages arising from the use of information in this catalog. Velan Valves, Velan, Memoryseal, Torqseal, Velflex, Adaxie, and RAMA are trademarks or registered trademarks of Velan Inc. and/or another Velan company. Stellite® is a registered trademark of Kennametal Stellite™, a wholly owned subsidiary of Kennametal Inc. All other trademarks and registered trademarks are owned by their respective companies.

## TABLE OF CONTENTS

Manufacturing plants .....	3
Principles of operation.....	4-5
How it works .....	6-7
Forged bimetallic steam traps, Types TS, TSF, and SF.....	8-11
Bimetallic steam traps, Type SSF .....	12, 17
Forged HP/HT steam traps, Type N .....	12, 15-17
Hermetically sealed steam traps, Types Q250 and UST .....	18-20
Velan connectors .....	21
High capacity piston operated steam traps Types SP and SPF .....	22-25
Piping King package units.....	26-29
Monovalve float bimetallic steam traps, Types MFT and MFTS .....	30-37
Thermodynamic steam traps, Types VTS, HPTD, VTDS, and VTD .....	38-41
Compressed air drain traps, Types MFA and MFAS .....	42-43
Strainers .....	44
Accessories .....	45
Comparison of principles of operation .....	47
Selection - sizing .....	48
Steam tables .....	49-50
How to order.....	51

# VELAN GLOBAL NETWORK

## Head office



Montreal, Canada  
Velan Inc.

- 17 production facilities
- 5 plants in North America
- 6 plants in Europe
- 6 plants in Asia
- 5 stocking and distribution centers
- Hundreds of distributors worldwide
- Over 60 service shops worldwide

## Manufacturing plants

### North America



Montreal, Canada  
Velan Inc., Plant 1



Montreal, Canada  
Velan Inc., Plant 2 and 7



Granby, Canada  
Velan Inc., Plant 4 and 6



Montreal, Canada  
Velan Inc., Plant 5



Williston, VT, U.S.A.  
Velan Valve Corp., Plant 3



### Europe



Lyon, France  
Velan S.A.S.



Mennecey, France  
Segault S.A.



Leicester, UK  
Velan Valves Ltd.



Lisbon, Portugal  
Velan Válvulas Industriais, Lda.



Lucca, Italy  
Velan ABV S.p.A., Plant 1



Lucca, Italy  
Velan ABV S.p.A., Plant 2

### Asia



Ansan City, South Korea  
Velan Ltd., Plant 1



Ansan City, South Korea  
Velan Ltd., Plant 2



Ansan City, South Korea  
Velan Ltd., Plant 3



Taichung, Taiwan  
Velan Valvac Mfg. Co., Ltd.



Suzhou, China  
Velan Valve (Suzhou) Co., Ltd.



Coimbatore, India  
Velan Valves India Pvt. Ltd.

## Distribution centers



Granby, Canada  
VelCAN



Benicia, CA, U.S.A.  
VelCAL



Marietta, GA, U.S.A.  
VelEAST



Houston, TX, U.S.A.  
VelTEX



Willich, Germany  
Velan GmbH

– ASME N-stamp accredited manufacturer

# PRINCIPLES OF OPERATION

## The Original "multi-segmented" bimetal principle actuates Velan steam traps

### WHAT IS BIMETAL?

- Bimetal is a composite metal comprising two or more metallic layers with different coefficients of expansion, which changes curvature when subjected to heat.

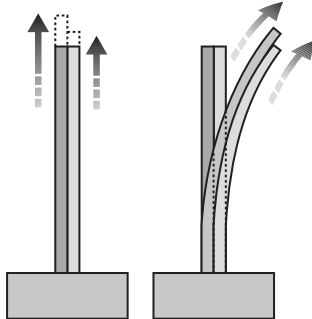

Velan steam traps use a bimetal of high tensile strength, stable at high temperature with deflection limited to 600°F (315°C) to prevent over-stressing in super-heated steam service.

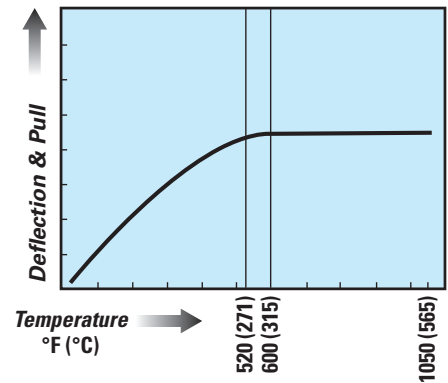

### THE CLOSING FORCE OF THE BIMETALLIC ELEMENTS FOLLOWS THE SATURATED STEAM CURVE

The force of line pressure acting on the valve ball holds it open when condensate or air is in the trap. Line pressure as well as valve and orifice diameter determine this force.

For a 1/2" (12.7 mm) orifice at 150 psig (10.3 barg) line pressure develops a force of 30 lb (134 N).

To close the valve on steam the bimetallic element must develop a pull of at least 35 lb (156 N) with three segments. The patented Velan multi-segment design was developed so that the thermal pull of the bimetal element would closely follow the saturated steam curve and use only the portion of the element required to overcome the opening force at saturated steam temperature.

A non-segmented bimetallic element would have a straight-line characteristic and the trap would only react to large temperature differentials, whereas the Velan two or three segmented element automatically compensates for any pressure condition within its range, and maintains the sensitivity to release condensate at below steam temperature without loss of steam.

**Chart 1** illustrates the truly universal operating principle behind the Velan steam trap. Each segment acts consecutively, covering the complete operating pressure range without adjustment or orifice change. With a single element the temperature differential to open the steam trap would be BC<sup>1</sup> (66°F/37°C) instead of BC (8°F/4.4°C) and the required closing force would be BA<sup>1</sup> (20 lb/90 N) instead of BA (5 lb/22 N).

**Chart 1** Operating principle of Velan steam traps

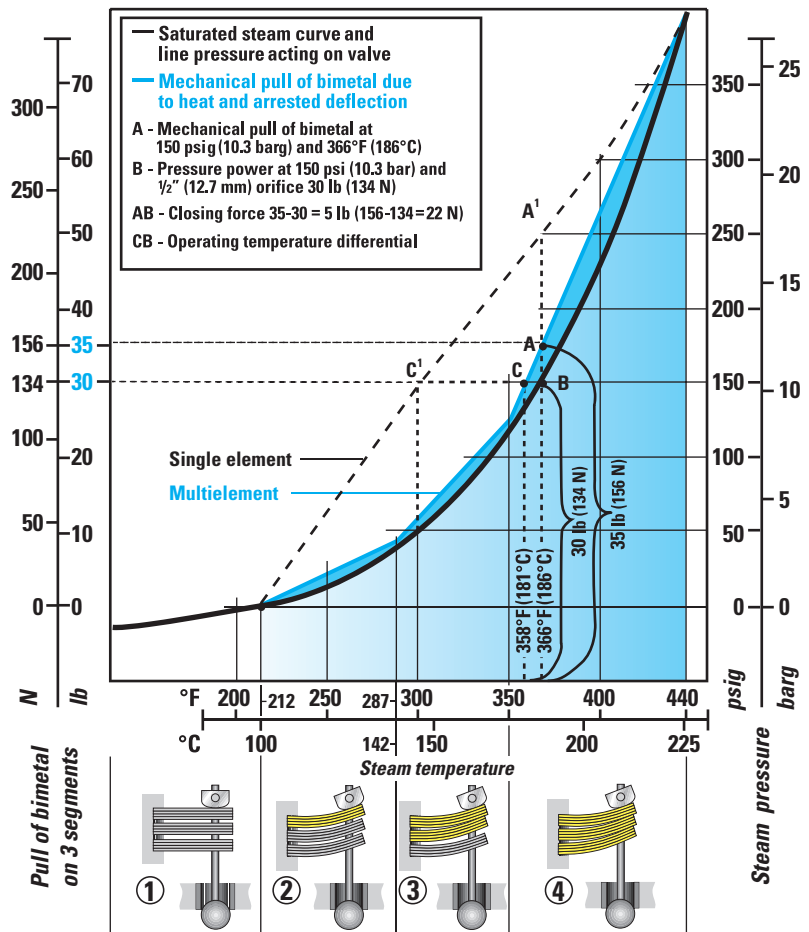

1. Free deflection up to 212°F (100°C)
2. One segment pulling 0-40 psig (0-2.8 barg) up to 287°F (142°C)
3. Two segments pulling 40-120 psig (2.28-8.3 barg) up to 350°F (177°C)
4. Three segments pulling 120-350 psig (8.3-24 barg) up to 440°F (227°C)

# PRINCIPLES OF OPERATION

## The Velan patented bimetal principle as applied to meet various requirements

### UNIVERSAL STEAM TRAP PRINCIPLE

● **Chart 2** illustrates the bimetal closing force developed at saturated temperature in relation to the line pressure tending to open the valve. The gradual increase in force, following the steam curve, is a function of the patented segmentation principle of the element. The delicate balance of opening and closing forces exists in all pressure ranges such as 0-200, 0-350, 0-600, 0-1500 psig (0-14, 0-21, 0-41, 0-103 barg), and produces complete universal operation throughout the pressure range without orifice change.

See page 4 for more details.

Chart 2 The patented multi-element principle.

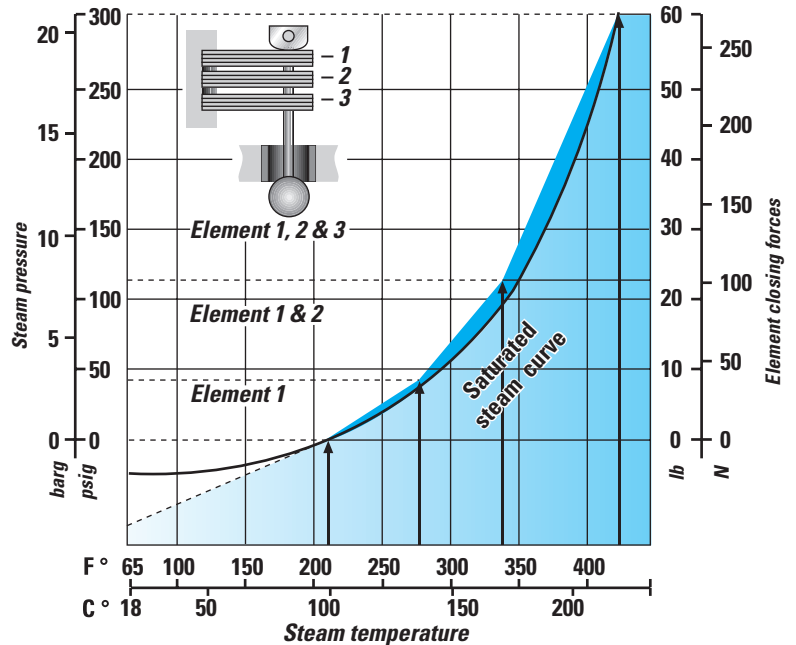
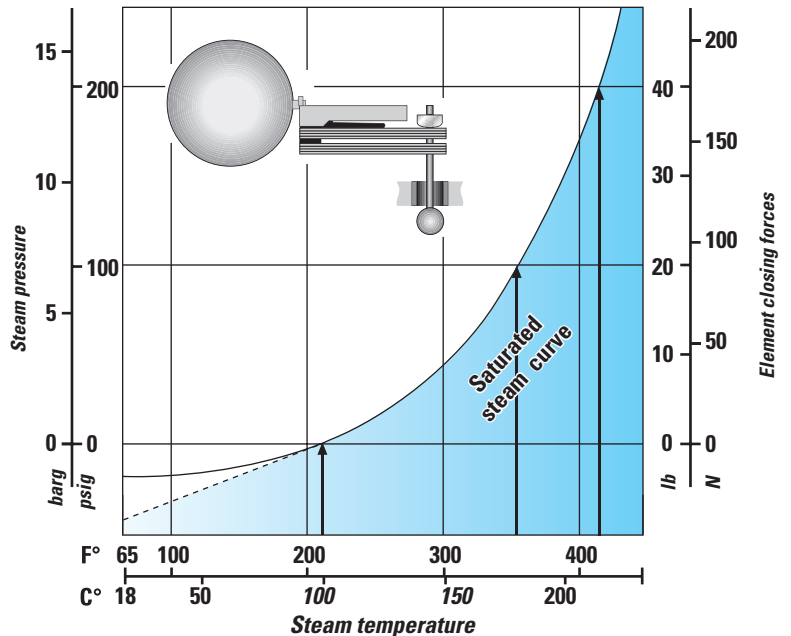

Chart 3 The patented multi-element principle combined with a float.

### FLOAT BIMETALLIC PRINCIPLE

● **Chart 3** illustrates the operation of the combination of a bimetal and float element used in the float/bimetallic series. In this principle, the bimetal is used to close the valve at saturated temperature or release cool air in the system. However a small accumulation of condensate in the trap body lifts the float and opens the discharge valve. No temperature depression is required for this process and, as a result, the characteristic is identical to the saturated steam curve. The steam trap shuts off in the presence of steam and opens at once in the presence of condensate even at saturated steam temperature.

See page 7 for more details.



# HOW IT WORKS

## The four purpose valve and its function in the Velan universal bimetallic steam trap

### FAST WARM UP

The discharge valve is open, allowing air and cold water to be discharged rapidly. The period of waiting to start a process is reduced to minutes—there is no air binding, water-logging, or steam locking to delay equipment warm up.

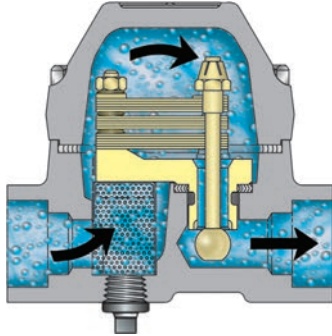

Actual tests show that up to 2½ hours may be saved on each “warm-up” because Velan steam traps have a much greater venting capacity than other traps, due to its large orifice.

### POSITIVE TRAPPING

Incoming steam causes the bimetal to deflect. This thermal pull of the bimetal element acts on the valve stem, overcoming the steam pressure closing the valve. The ball valve is pulled tightly on to its seat, preventing weeping and loss of live steam.

The thermal pull increases or decreases as a function of temperature, in the same relation as the temperature and pressure of the saturated steam.

The same element can be used for varying steam pressures within wide pressure ranges.

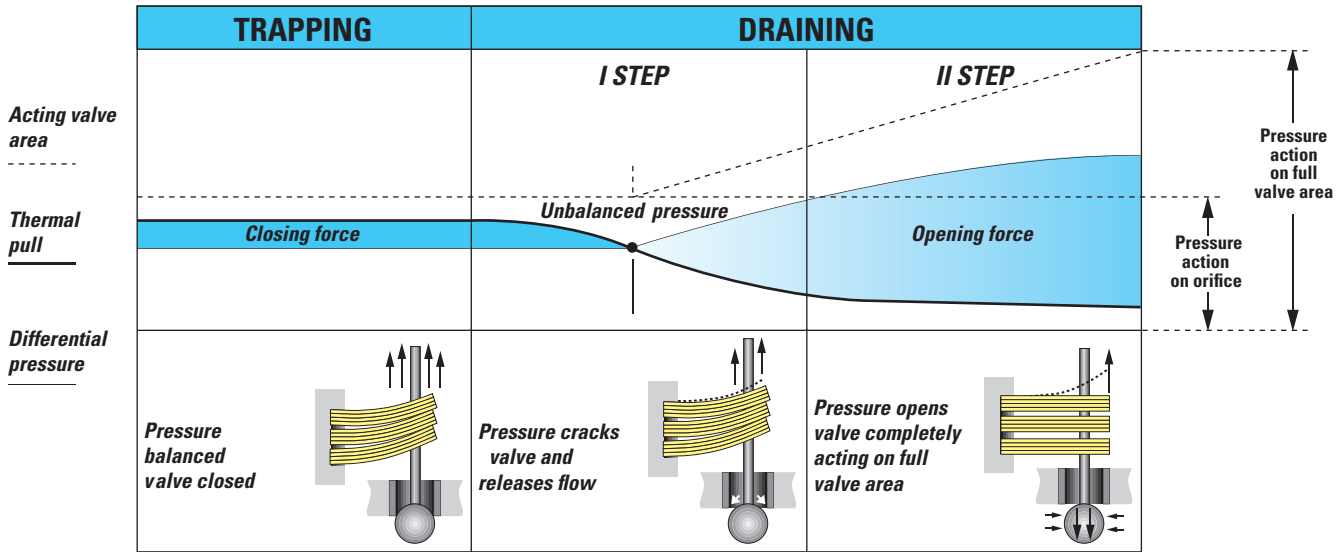
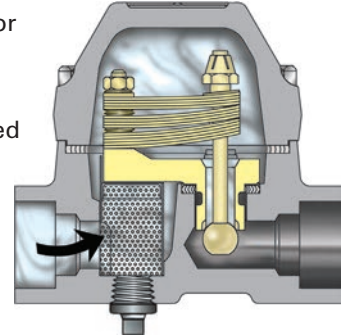

### TWO-STEP DRAINAGE

When steam condenses into water, the thermal pull of the bimetal is gradually reduced until the line pressure on the valve releases it from the valve seat and allows condensate to be discharged.

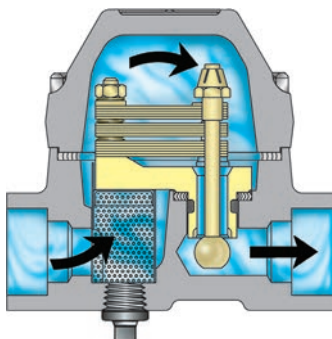

This is the first step in the smooth and quick opening of the valve, without noise or violent action. When the flow is released, the unbalanced pressure acts on the full valve area. The force to overcome the thermal pull increases and opens the orifice to full capacity.

### CHECK VALVE ACTION

Back pressure in the discharge pipe, a sudden drop or rapid fluctuation in steam pressure, or discharging to overhead lines causes back flow of condensate.

To prevent this possible back flow of condensate entering the equipment when it's not in service, separate check valves have to be installed as near to the trap as possible. In Velan steam traps, the discharge valve in the trap acts as a check valve, thereby providing full back flow control.

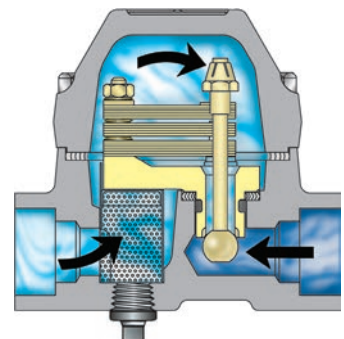

# HOW IT WORKS

## The four purpose valve and its function in the Velan piston operated and the monovalve float bimetallic steam trap

### PISTON OPERATED

Cool air and condensate from the system is discharged through the large main valve orifice actuated by the piston, which is held open by its own weight when cold. As line pressure builds up, pressure above the piston keeps the valve open at maximum discharge until the system is completely purged of air and condensate.

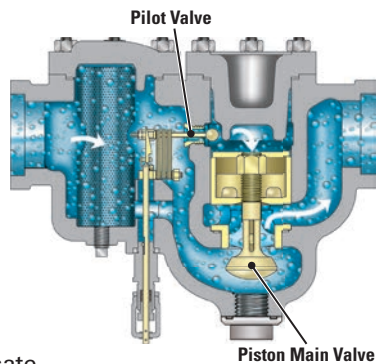

### MONOVALE FLOAT BIMETALLIC

#### FAST WARM UP

Clearing air and moisture from a cold system rapidly reduces warm up time and increases production. While other float traps must have a separate air venting facility, Velan's MFT utilizes the large main orifice for the fastest warm up time of any comparably sized float trap.

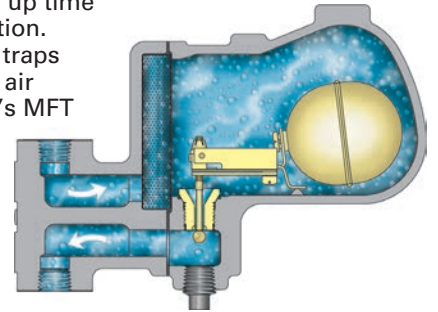

#### POSITIVE TRAPPING

Incoming steam contacting the bimetal element closes the pilot valve, thereby reducing the pressure acting on the piston. Line pressure below the main valve closes it tightly but smoothly, due to the partial pressure remaining in the piston chamber.

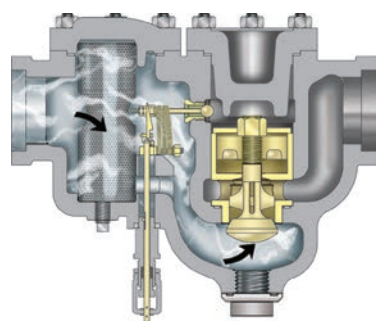

When condensate is discharged, the float mechanism rests on the trap body. The bimetal element alone closes the valve with thermal power developed by incoming steam. The bimetal element is a function of the saturated steam curve, and therefore operates efficiently at any pressure within its range.

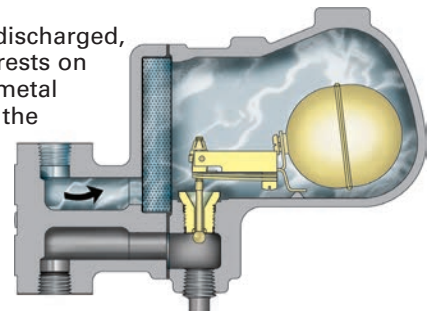

#### CONDENSATE DISCHARGE

When condensate and air collect in the trap body, the bimetal force is reduced, and line pressure opens the pilot valve, pressurizing the piston chamber and forcing the main valve open against line pressure by virtue of the greater piston area.

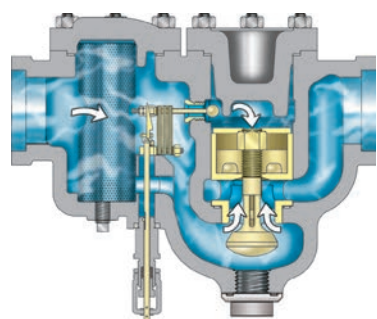

If condensate builds up in the trap body, the float becomes buoyant and opens the valve to unrestricted flow. Condensate even at steam temperature is discharged at the same rate as it reaches the trap. There is no air binding or water logging even in adverse conditions. The trap drains by gravity and **will not freeze**.

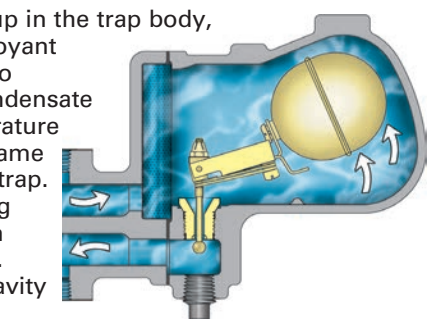

#### CHECK VALVE ACTION

Excess back pressure, a drop in line pressure, or discharging to overhead return lines can cause a reverse flow of condensate through the trap. Normally, separate check valves are required to prevent this occurrence. The Velan type SP main discharge valve also works as a temporary piston check valve and prevents back flow.

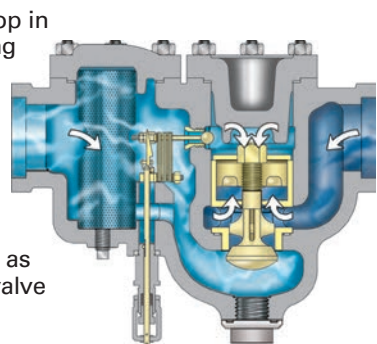

When pressure is off, equipment discharging to a common return, or where condensate is returned to overhead lines, a check valve is required to prevent reverse flow through the trap. The free-floating MFT mechanism shuts immediately the reverse flow and no additional device is required.

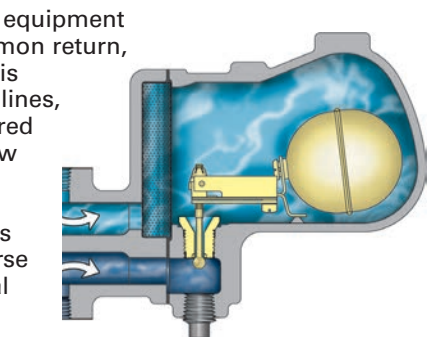

# VELAN FORGED BIMETALLIC CAGE UNIT STEAM TRAPS

## CAGE UNIT ON TYPE TS, TSF, AND SF

### CAGE UNIT

The advanced cage unit design in Velan steam traps combines a bimetal element, hardened Rc 58 min. ball valve, and a CoCr alloy hardfaced seat area all in one factory-tested assembly.

Replacement of all wearing parts can be achieved in less than two minutes, with the trap remaining in-line.

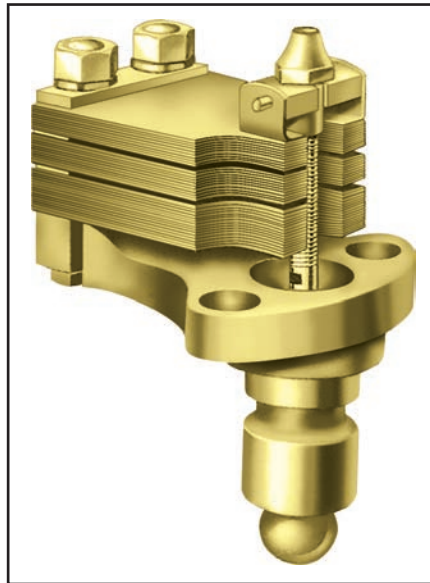

### TS, TSF, AND SF DESIGN FEATURES

- **Forged valve body and cover**  
offer the advantages of high strength, structural integrity and reliability that make it an ideal choice for steam service.
- **Stainless steel trim**
- **Seat CoCr alloy hardfaced**  
Increases resistance to the high degree of wear through velocity of flow, dirt, and scale.
- **Integral strainer (F)**  
Stainless steel screens are integral in all three models to protect the trap operating mechanism from damage by dirt or scale. No extra fittings or installation costs are required. Free strainer area minimum 5 to 1. Perforation is 0.031" (0.8 mm).
- **Unique operation**  
The individual segments of the bimetallic element act consecutively, developing forces in close relation to the saturated steam curve. This permits sensitive, efficient trap operation at all pressures from 1 psig to maximum, without orifice change.
- **Silent operation** – No violent line shocks.
- **Positive closing**  
Every Velan steam trap closes tightly on saturated steam temperature. Positive closing for long periods on dry superheated steam has enormous advantages in power plant and marine service.
- **All-position operation** simplifies piping layout.

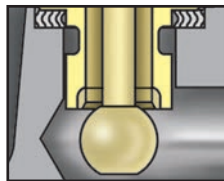

- **Freeze-proof**  
Velan traps do not require a reservoir of priming water in the body to operate. When installed vertically with inlet on top, they drain completely when cold, and are freeze-proof without insulation.
- **Positive condensate drainage** for process work.
- **Optional temperature controller on SF**  
An ingenious device that allows adjustment of factory setting under full steam pressure. Condensate discharge temperature can be increased or decreased to meet the specific requirements of any process application. Up to 30% of energy can be saved by extracting the sensible heat of steam.
- **Other options include:**  
Strainer blowdown valve. Piping King Units complete with valving.

**SERVICE:  
2 MINUTES  
TO  
REPLACE  
CAGE UNIT**

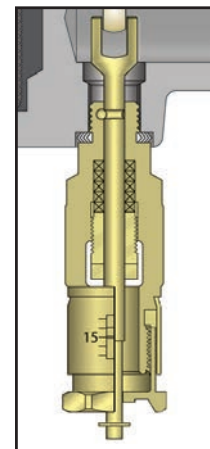
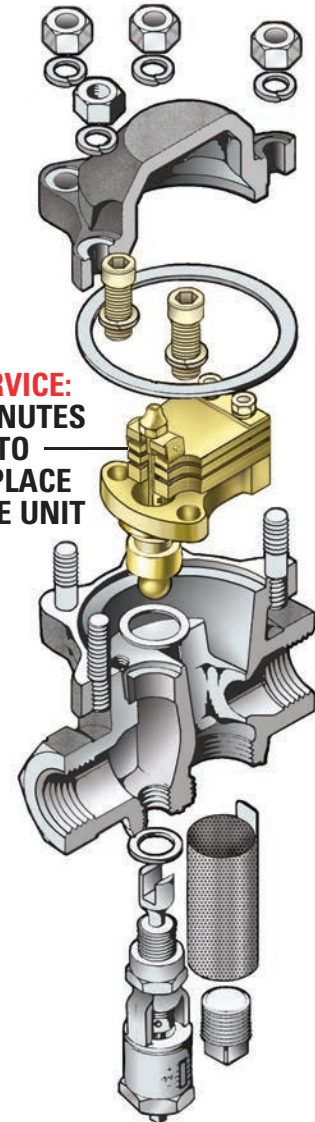

**NOTE:** CoCr alloy as used throughout this catalog refers to cobalt chrome hardfacing alloys as supplied by Kennametal Stellite, and other approved manufacturers.



# VELAN FORGED TS STEAM TRAPS

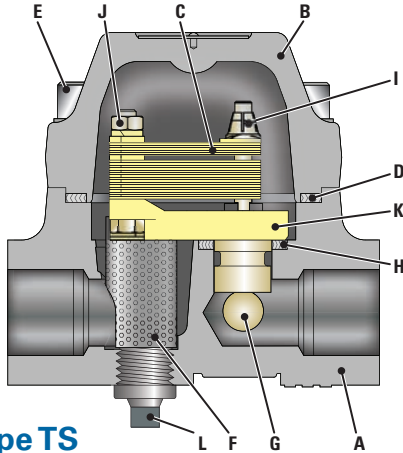

## STANDARD MATERIALS

PART	MATERIALS
A	Body Forged carbon steel A 105 (C. Max. 0.25)
B	Cover Same as body material
C	Bimetal element Truflex GB-14
D	Cover gasket SS 316 core with graphite seal
E	Cover bolt Chrome moly. alloy B7
F	Strainer Stainless steel
G	Stem and ball SS, ball valve 58 Rc min.
H	Cage unit gasket SS 316 core with graphite seal
I	Self-lock adjusting nut Stainless steel
J	Fixing screw Stainless steel
K	Bimetal holder <sup>(1)</sup> Stainless steel
L	Plug 3/8 NPT Carbon steel

(1) Seat hardfaced CoCr alloy.

## APPLICATIONS

Boiler headers, steam mains, branch lines, tracer lines, sterilizers and finned radiation.

## CONNECTIONS

- Screwed
- Socket-weld
- Butt-weld
- Flanged

## Type TS

## ENGINEERING DATA

PRESSURE RANGE <sup>(2)</sup> psig/barg	PMO psig/barg	MATERIAL	MAX TEMP °F/°C	ORIFICE in/mm	MAX CAPACITY lb/hr/kg/hr
0-20 (0-1.4)	20 (1.4)	A105	850 <sup>(1)</sup> 454	3/8 9.5	800 364
0-120 (0-8)	120 (8)			3/8 9.5	1,650 750
0-250 (0-17)	250 (17)			5/16 8	1,500 682
0-300 (0-21)	300 (21)			5/16 8	1,700 773

(1) Permissible, but not recommended for prolonged use above 800°F (426°C).

(2) Product will operate throughout entire pressure range, however selection closest to the Maximum operating pressure is recommended for maximum efficiency.

Maximum body design condition: ANSI/ASME 300 (A105)  
 PMA = Maximum allowable pressure: 740psig @ 100°F (51barg @ 38°C)  
 TMA = Maximum allowable temperature: 800°F (425°C)  
 Maximum cold hydrostatic test pressure: 1125psig (77barg)  
 PMO = Maximum operating pressure: (see Engineering data table)  
 TMO = Maximum operating temperature = TMA

## DIMENSIONS AND WEIGHTS

Clearance for strainer removal:  
TS 4 1/8 in (105 mm) min.

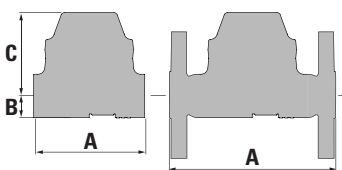

SIZE NPS/DN	A FACE TO FACE			B CENTER TO BOTTOM	C CENTER TO TOP	WEIGHT lb/kg		
	SCR/SW	BW	FLG			SCR/SW	BW	FLG
3/8 1/2 3/4	4	10	6	1 1/2	3	6	8	10
10 15 20	102	254	152	38	76	2.7	3.6	4.5
1	4	10	6	1 3/4	3 1/4	6.5	9	13
25	102	254	152	44	83	3	4	6

## CONDENSATE CAPACITY

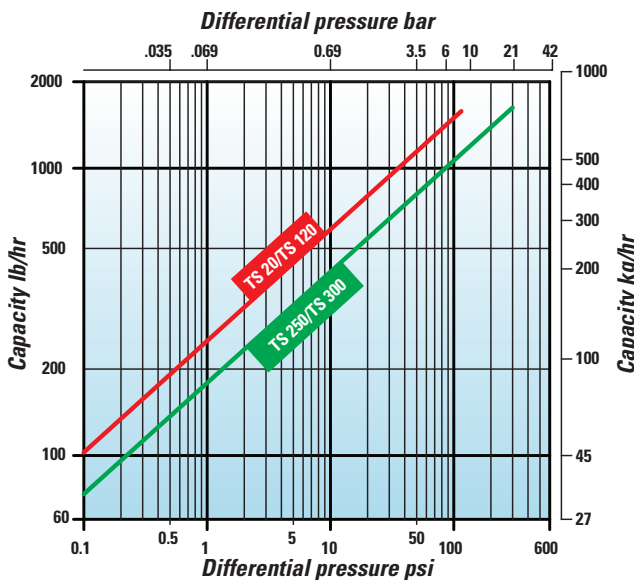

Maximum cold water capacity x 3.5

The performance graph indicates the continuous discharge capacities of condensate per hour at various pressure differentials across the trap.

## PRESSURE / TEMPERATURE LIMITS

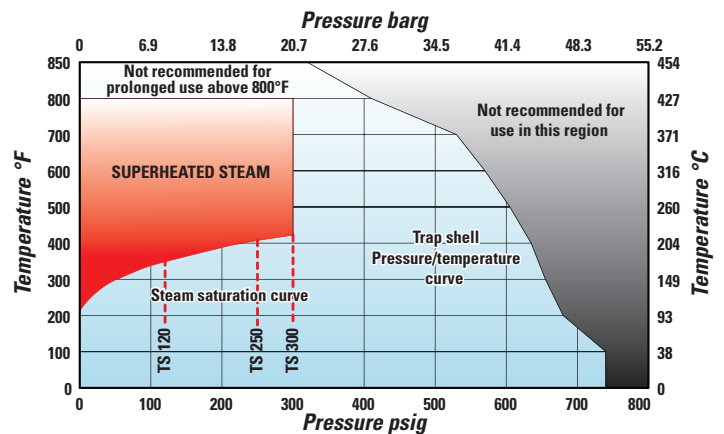

----- Pressure limit for trap type

# VELAN FORGED TSF STEAM TRAPS

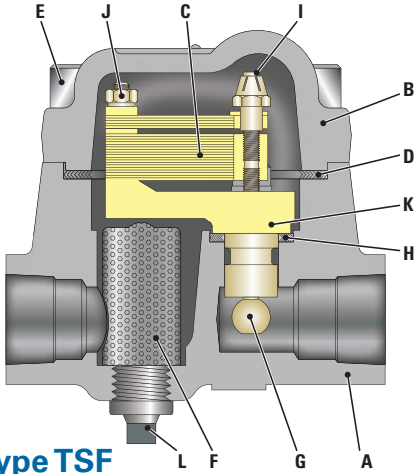

Type TSF

## STANDARD MATERIALS

PART	MATERIALS
A	Body Forged carbon steel A 105 (C. Max. 0.25)
B	Cover Same as body material
C	Bimetal element Truflex GB-14
D	Cover gasket SS 321 spiral wound with graphite filler
E	Cover bolt Chrome moly. alloy
F	Strainer Stainless steel
G	Stem and ball SS, ball valve 58 Rc min.
H	Cage unit gasket SS 321 spiral wound with graphite filler
I	Self-lock adjusting nut Stainless steel
J	Fixing screw Stainless steel
K	Bimetal holder <sup>(1)</sup> Stainless steel
L	Plug 3/8 NPT Carbon steel

(1) Seat hardfaced CoCr alloy.

## APPLICATIONS

Boiler headers, steam mains, branch lines and tracer lines.

## CONNECTIONS

- Screwed
- Socket-weld
- Butt-weld
- Flanged

## ENGINEERING DATA

PRESSURE RANGE <sup>(2)</sup> psig/barg	PMO psig/barg	MATERIAL	MAX TEMP °F/°C	ORIFICE in/mm	MAX CAPACITY lb/hr/kg/hr
0-200 (0-14)	200 (14)	A105	850 <sup>(1)</sup> 454	3/8 9.5	2,000 909
0-485 (0-33.5)	485 (33.5)			1/4 6.4	1,400 636

(1) Permissible, but not recommended for prolonged use above 800°F (426°C).

(2) Product will operate throughout entire pressure range, however selection closest to the Maximum operating pressure is recommended for maximum efficiency.

Maximum body design condition: ANSI/ASME 400  
 PMA = Maximum allowable pressure: 990psig@100°F (68bar@38°C)  
 TMA = Maximum allowable temperature: 800°F (427°C)  
 Maximum cold hydrostatic test pressure: 1500psig (103 barg)  
 TMO = Maximum operating temperature = TMA  
 PMO = Maximum operating pressure: (See Engineering data table)

Clearance for strainer removal:  
SF 4 1/2 in (114 mm) min.

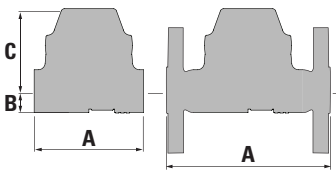

## DIMENSIONS AND WEIGHTS

SIZE NPS/DN	A FACE TO FACE			B CENTER TO BOTTOM	C CENTER TO TOP	WEIGHT lb/kg		
	SCR/SW	BW	FLG			SCR/SW	BW	FLG
1/2 3/4	4 3/8	10 3/8	7 3/8	1	3 1/2	8	9	14
15 20	111	264	187	25	89	3.6	4	6.4

## CONDENSATE CAPACITY

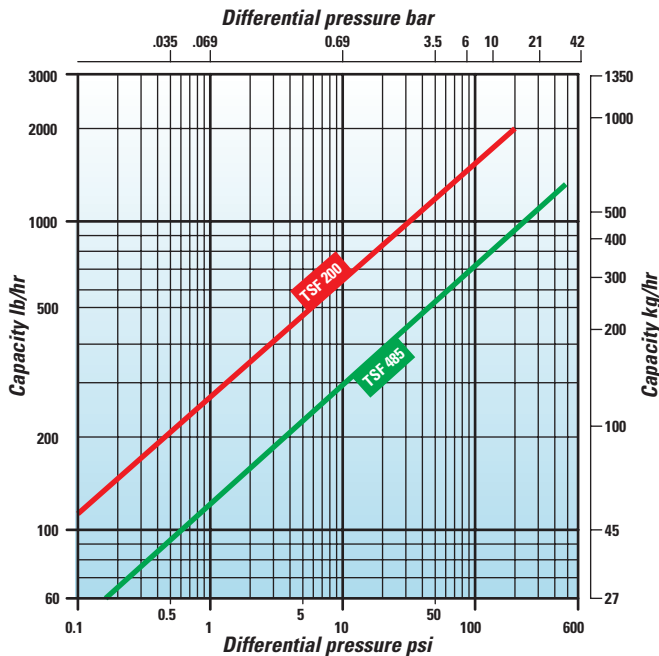

Maximum cold water capacity x 3.5

The performance graph indicates the continuous discharge capacities of condensate per hour at various pressure differentials across the trap.

## PRESSURE / TEMPERATURE LIMITS

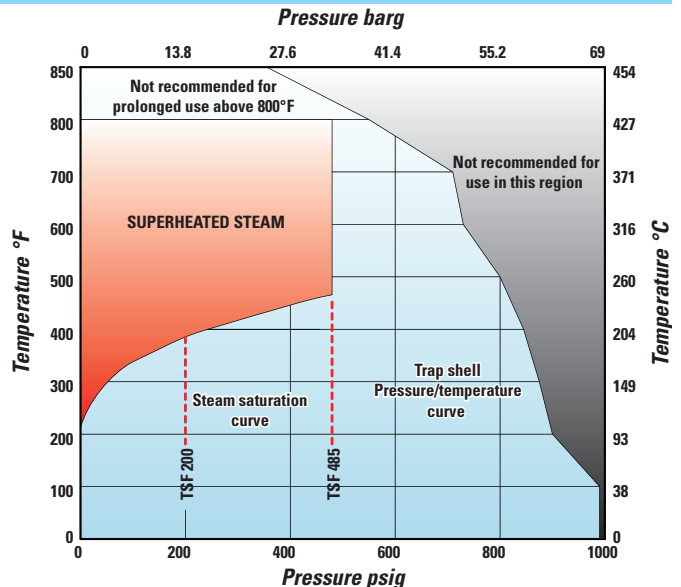

----- Pressure limit for trap type

# VELAN FORGED SF STEAM TRAPS

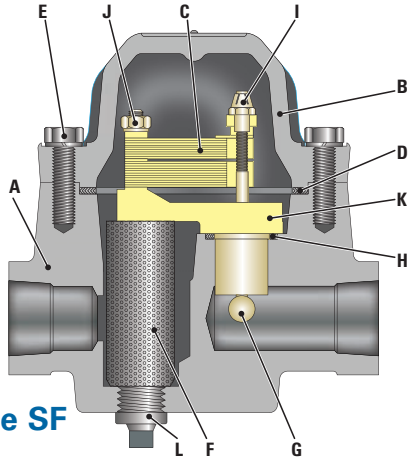

Type SF

## STANDARD MATERIALS

PART		MATERIALS
A	Body	Forged carbon steel A 105 (C. Max. 0.25)
B	Cover	Same as body material
C	Bimetal element	Truflex GB-14
D	Cover gasket	SS 316 core with graphite seal
E	Cover bolt <sup>(1)</sup>	Chrome moly. alloy
F	Strainer	Stainless steel
G	Stem and ball	SS, ball valve 58 Rc min.
H	Cage unit gasket	SS 316 core with graphite seal
I	Self-lock adjusting nut	Stainless steel
J	Fixing screw	Stainless steel
K	Bimetal holder <sup>(2)</sup>	Stainless steel
L	Plug 3/8 NPT	Carbon steel

(1) B7-ANSI CLASS 300, SB637- ANSI CLASS 400.  
 (2) Seat hardfaced CoCr alloy.

## APPLICATIONS

Boiler headers, steam mains, branch lines, steam separators and intermediate stage turbine drains.

## CONNECTIONS

- Screwed
- Socket-weld
- Butt-weld
- Flanged

## ENGINEERING DATA

PRESSURE RANGE <sup>(2)</sup> psig/barg	PMO psig/barg	MATERIAL	MAX TEMP °F/°C	ORIFICE in/mm	MAX CAPACITY lb/hr/kg/hr
0-50 (0-3.5)	50 (3.5)	A105	850 <sup>(1)</sup> 454	3/4 19	3,250 1,477
0-150 (0-10.4)	150 (10.4)			1/2 12.7	3,250 1,477
0-300 (0-21)	300 (21)			1/2 12.7	4,500 2,045

(1) Permissible, but not recommended for prolonged use above 800°F (427°C).  
 (2) Product will operate throughout entire pressure range, however selection closest to the Maximum operating pressure is recommended for maximum efficiency.

PRESSURE RANGE psig/barg	PMO psig/barg	MATERIAL	MAX TEMP °F/°C	ORIFICE in/mm	MAX CAPACITY lb/hr/kg/hr
0-400 (0-28)	400 (28)	A105	850 <sup>(1)</sup> 454	3/8 9.5	3,100 1,409
0-600 (0-42)	600 (42)			5/16 8	2,600 1,182

Maximum body design condition: ANSI/ASME 300 (B7)  
 PMA = Maximum allowable pressure: 740psig @100°F (51bar @ 38°C)  
 Maximum cold hydrostatic test pressure: 1125psig (77bar)  
 Maximum body design condition: ANSI/ASME 400 (SB637)  
 PMA = Maximum allowable pressure: 990psig @ 100°F (68bar @ 38°C)  
 Maximum cold hydrostatic test pressure: 1500psig (103bar)  
 TMA = Maximum allowable temperature: 800°F (425°C)  
 PMO = Maximum operating pressure: (see Engineering data table)  
 TMO = Maximum operating temperature = TMA

Clearance for strainer removal:  
 SF 6 in (152 mm) min.

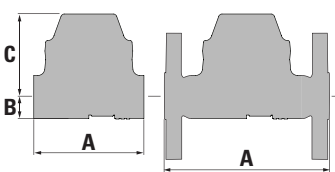

## DIMENSIONS AND WEIGHTS

SIZE NPS/DN	A FACE TO FACE			B CENTER TO BOTTOM	C CENTER TO TOP	WEIGHT lb/kg		
	SCR/SW	BW	FLG			SCR/SW	BW	FLG
1/2 3/4 1 15 20 25	6 1/8 156	12 1/8 308	8 1/8 <sup>(1)</sup> 206	2 1/8 54	4 3/4 121	13 6	16 7	21 <sup>(2)</sup> 9.5

(1) SF300/600 FLG: 9 1/8 in (232 mm). (2) SF300/600 FLG: 23lb (10.4KG).

## CONDENSATE CAPACITY

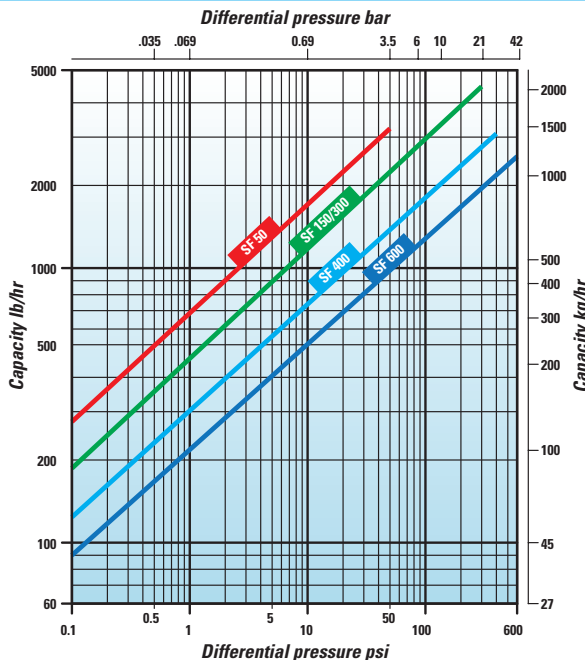

The performance graph indicates the continuous discharge capacities of condensate per hour at various pressure differentials across the trap.

## PRESSURE / TEMPERATURE LIMITS

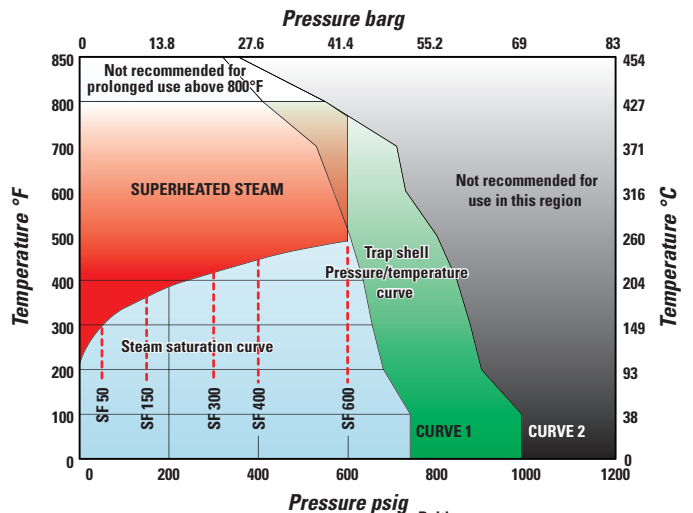

Bolting:  
 ASME SA193 B7 - Curve 1: Ansi 300,  
 ASME SB637 N07718 - Curve 2: Ansi 400

----- Pressure limit for trap type

# VELAN BIMETALLIC STEAM TRAPS

## BIMETALLIC ELEMENT ON TYPE SSF, N150, N675, N900, N2500, N2600, AND N4000

### BIMETAL ELEMENT

The individual segments of the bimetallic element act consecutively, developing forces in close relation to the saturated steam curve. This permits sensitive, efficient trap operation at all pressures.

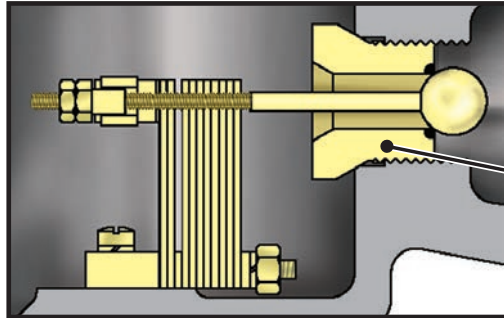

**Separate seat**  
**Screwed  $\leq 600$  psi**  
**Welded  $> 600$  psi**

### COMMON DESIGN FEATURES

- **Automatic air venting: Good discharge capacity**  
Air and cold condensate is discharged through a full orifice efficiently ensuring fast warm-up of equipment.
- **Integral strainer**  
An integral stainless steel strainer protects the trap operating mechanism from damage by dirt or scale. No extra fittings or installation costs are required. Free strainer area minimum 5 to 1. Perforation is 0.031" (0.8 mm).
- **All-position installation**  
Simplifies piping layout.
- **Silent operation**  
No violent line shocks.
- **Freeze-proof in vertical position: Inlet on top**  
Without insulation—complete drainage when cold.
- **Positive closing**  
Every Velan trap closes tightly on saturated steam temperature. Positive closing for long periods on dry superheated steam has enormous advantages in power plant and marine service.
- **Seat CoCr alloy hardfaced**  
Increases resistance to the high degree of wear through velocity of flow, dirt, and scale.
- **Positive condensate drainage**
- **Silent operation**  
No violent line shocks.
- **Trim**  
Stainless steel with ball 58 Rc min.

### TYPE SSF FEATURES

- **Easy internal maintenance**  
The removal of the body cover provides easy access to the bimetallic element and seat. The removal of the strainer cover permits quick and easy removal of the strainer.
- **Optional temperature controller**  
An ingenious device that can be adapted to most Velan models permits adjustment of factory settings under full steam pressure. Condensate discharge temperature can be increased or decreased to meet the specific requirements of any process application. Up to 30% of energy can be saved by extracting the sensible heat of steam.
- **Optional extras**  
Thermometer, strainer blowdown valve and Piping King Units complete with valving.

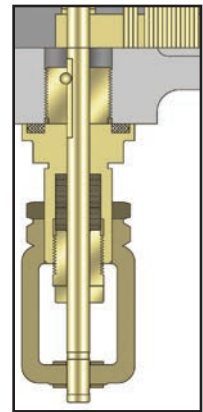

### TYPE N DESIGN FEATURES

- **Easy access**  
to all the internal operating parts when the body cover is removed.
- **Forged valve body and cover**  
offer the advantages of high strength, structural integrity and reliability that make it an ideal choice for steam service.
- **Other options**  
NPT blow down plug, strainer blowdown valve and Piping King Unit with all valving.

# VELAN BIMETALLIC SSF STEAM TRAPS

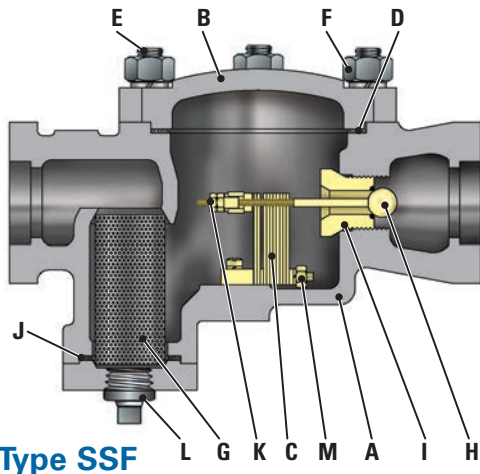

Type SSF

## STANDARD MATERIALS

PART	MATERIALS
A	Body Cast carbon steel WCB (C. Max. 0.25)
B	Cover Carbon steel
C	Bimetal element Truflex GB-14
D	Cover gasket SS 321 spiral wound with graphite filler
E	Cover stud Chrome moly. alloy B7
F	Cover nut Carbon steel 2H
G	Strainer Stainless steel
H	Stem and ball SS, ball valve 58Rc
I	Seat SS hardfaced CoCr alloy
J	Strainer cover gasket SS 321 spiral wound with graphite filler
K	Adjusting nut and locknut Stainless steel
L	Strainer blow down plug Carbon steel
M	Fixing screw and washer Stainless steel

## APPLICATIONS

Boiler headers, steam mains, branch lines, steam separators, oil storage tank coils, purifiers, de-superheater drains, reboilers, feed water heaters, heat exchangers and cold reheat drains.

## CONNECTIONS

- Screwed
- Socket-weld
- Butt-weld
- Flanged

## ENGINEERING DATA

PRESSURE RANGE <sup>(2)</sup> psig/barg	PMO psig/barg	MATERIAL	MAX TEMP °F/°C	ORIFICE in/mm	MAX CAPACITY lb/hr/kg/hr
0-125 (0-8.5)	125 (8.5)	WCB	850 <sup>(1)</sup> 454	1	5,750
0-200 (0-14)	200 (14)			25	2,608
				7/8	6,400
0-400 (0-28)	400 (28)			22	2,903
0-600 (0-42)	600 (42)			9/16	5,300
		14	2,409		
		1/2	5,200		
		12.7	2,360		

Maximum body design condition: ANSI/ASME 400  
 PMA = Maximum allowable pressure: 990psig@100°F (68bar@38°C)  
 TMA = Maximum allowable temperature: 800°F (427°C)  
 Maximum cold hydrostatic test pressure: 1500psig (103bar)  
 TMO = Maximum operating temperature = TMA  
 PMO = Maximum operating pressure: (See Engineering data table)

(1) Permissible, but not recommended for prolonged use above 800°F (427°C).

(2) Product will operate throughout entire pressure range, however selection closest to the Maximum operating pressure is recommended for maximum efficiency.

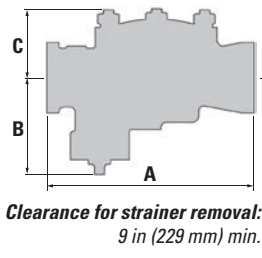

Clearance for strainer removal:  
9 in (229 mm) min.

## DIMENSIONS AND WEIGHTS

TYPE	SIZE NPS/DN	A FACE TO FACE			B CENTER TO BOTTOM	C CENTER TO TOP	WEIGHT lb/kg		
		SCR/SW	BW	FLG			SCR/SW	BW	FLG
SSF 125	2 50								
SSF 200 SSF 400 SSF 600	1 1/2 40	11 279	17 432	14 1/4 362	5 3/8 137	3 1/2 89	30 14	33 15	40 18
	2 50								

## CONDENSATE CAPACITY

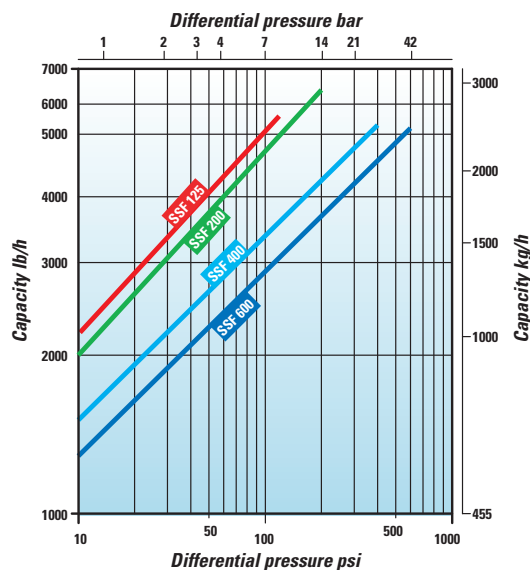

Maximum cold water capacity x 3.5

The performance graph indicates the continuous discharge capacities of condensate per hour at various pressure differentials across the trap.

## PRESSURE / TEMPERATURE LIMITS

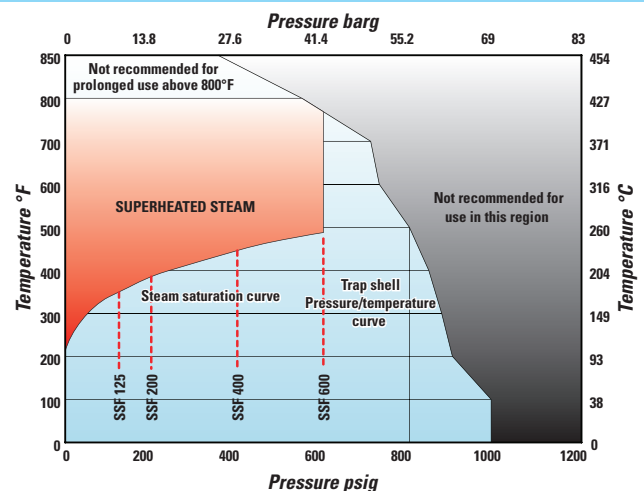

----- Pressure limit for trap type

# VELAN FORGED BIMETALLIC N150-300 STEAM TRAPS

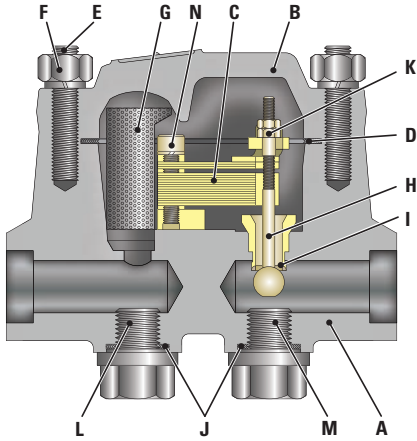

Type N150/300

## STANDARD MATERIALS

PART	MATERIALS
A Body	Forged carbon steel A105 (C. Max. 0.25) Forged alloy steel F22
B Cover	Same as body material
C Bimetal element	Truflex GB-14
D Cover gasket	SS 321 spiral wound with graphite filler
E Cover stud <sup>(1)</sup>	Chrome moly. alloy
F Cover nut <sup>(1)</sup>	Carbon steel, alloy steel
G Strainer	Stainless steel
H Stem and ball	SS, ball valve 58Rc
I Seat	SS hardfaced CoCr alloy
J Plug gasket	SS 321 spiral wound with graphite filler
K Adjusting nut and locknut	Stainless steel
L Strainer blow down plug	Same as body material
M Test plug	Same as body material
N Fixing screw and washer	Stainless steel

(1) B7/2H (A105), B16/Gr.4 (F22).

## APPLICATIONS

Boiler headers, steam mains, branch lines, soot blower drains and intermediate stage turbine drains.

## CONNECTIONS

- Screwed
- Socket-weld
- Butt-weld
- Flanged

## ENGINEERING DATA

PRESSURE RANGE <sup>(3)</sup> psig/barg	PMO psig/barg	MATERIAL	MAX TEMP F/C	ORIFICE in/mm	MAX CAPACITY lb/hr/kg/hr
0-150 (0-10.5)	150 (10.5)	A105 <sup>(1)</sup>	850 <sup>(2)</sup> 454	1/2 12.7	2,800
0-300 (0-21)	300 (21)				1,272
					3,500
					1,590

Maximum body design condition: ANSI/ASME 400  
 PMA = Maximum allowable pressure: 1000psig@100°F (69bar@38°C)  
 TMA = Maximum allowable temperature: 800°F (427°C) – A105  
 1050F (565C) – F22  
 Maximum cold hydrostatic test pressure: 1500psig (103bar)  
 TMO = Maximum operating temperature = TMA  
 PMO = Maximum operating pressure: (See Engineering data table)

(1) Also available in F22, max temp. 1050°F (565°C). (2) Permissible, but not recommended for prolonged use above 800°F (426°C).

(3) Product will operate throughout entire pressure range, however selection closest to the Maximum operating pressure is recommended for maximum efficiency.

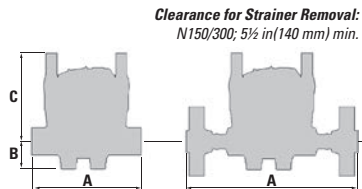

## DIMENSIONS AND WEIGHTS

SIZE NPS/DN	A FACE TO FACE			B CENTER TO BOTTOM	C CENTER TO TOP	WEIGHT lb/kg		
	SCR/SW	BW	FLG			SCR/SW	BW	FLG
1/2 15	7 1/4 184	13 1/4 337	11 1/4 286	2 51	4 1/2 115	24 11	26 12	37 17

## CONDENSATE CAPACITY

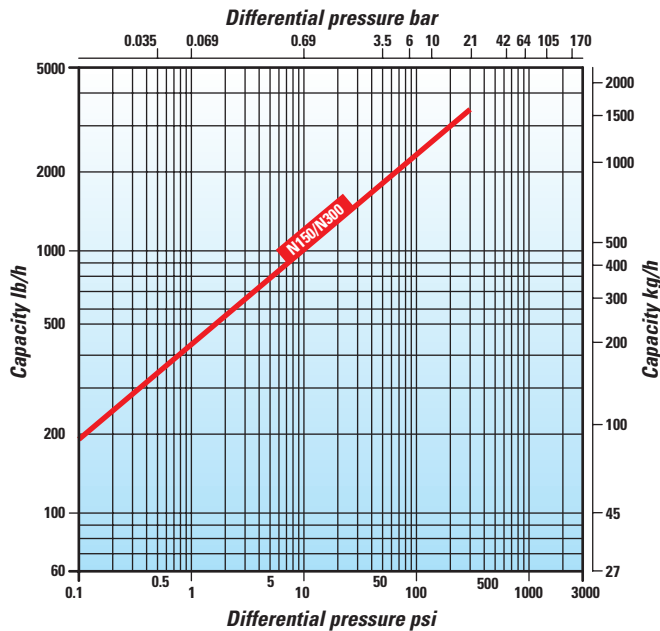

Maximum cold water capacity x 3.5

The performance graph indicates the continuous discharge capacities of condensate per hour at various pressure differentials across the trap.

## PRESSURE / TEMPERATURE LIMITS

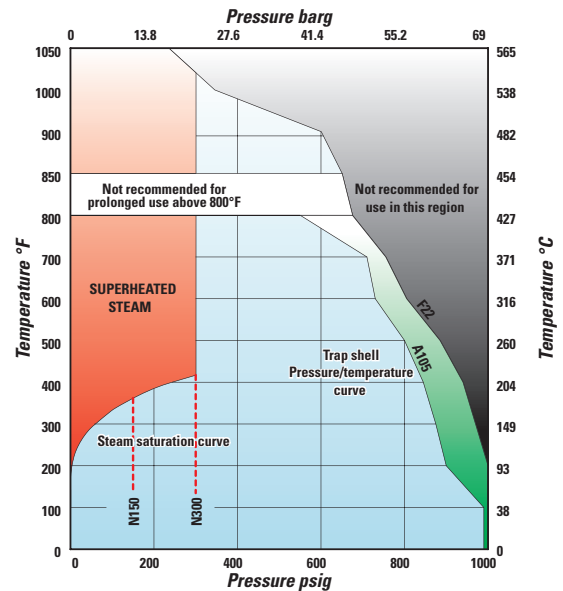

----- Pressure limit for trap type

# VELAN FORGED HP/HT N675-1500 STEAM TRAPS

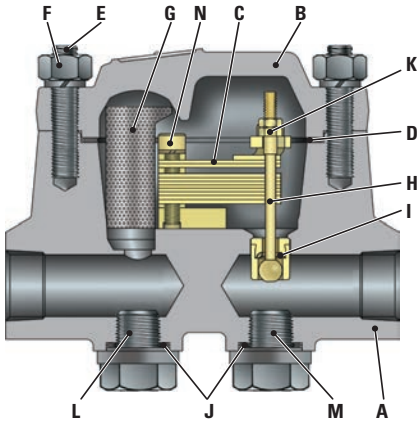

## STANDARD MATERIALS

PART	MATERIALS
A Body	Forged carbon steel A105 (C. Max. 0.25) Forged alloy steel F22
B Cover	Same as body material
C Bimetal element	Truflex GB-14
D Cover gasket	SS 321 spiral wound with graphite filler
E Cover stud <sup>(1)</sup>	Chrome moly. alloy
F Cover nut <sup>(1)</sup>	Carbon steel, Stainless steel
G Strainer	Stainless steel
H Stem and ball	SS, ball valve 58Rc
I Seat	SS hardfaced CoCr alloy
J Plug gasket	SS 321 spiral wound with graphite filler
K Adjusting nut and locknut	Stainless steel
L Strainer blow down plug	Same as body material
M Test plug	Same as body material
N Fixing screw and washer	Stainless steel

## APPLICATIONS

Boiler headers, steam mains, branch lines, soot blower drains and intermediate stage turbine drains.

## CONNECTIONS

- Screwed
- Socket-weld
- Butt-weld
- Flanged

## Type N675-1500

## ENGINEERING DATA

PRESSURE RANGE <sup>(3)</sup> psig/barg	PMO psig/barg	MATERIAL	MAX TEMP °F/°C	ORIFICE in/mm	MAX CAPACITY lb/hr/kg/hr
0-675 (0-46.5)	675 (46.5)	A105 <sup>(1)</sup>	850 <sup>(2)</sup> 454	5/16 8	2,900 1,315
0-900 (0-62)	900 (62)			1/4 6.4	1,850 841
0-1500 (0-103)	1500 (103)				2,100 955

### Standard bolting: B7/B16

PMA = Maximum allowable pressure: 1830psig@100°F (126bar@38°C)  
TMA = Maximum allowable temperature: 800°F (427°C) – A105  
1050°F (565°C) – F22

Maximum cold hydrostatic test pressure: 2750psig (190bar)  
TMO = Maximum operating temperature = TMA  
PMO = Maximum operating pressure: (See Engineering data table)

### Special bolting: SB637

Maximum design condition: ANSI/ASME 1500  
PMA = Maximum allowable pressure: 3705psig@100°F (255bar@38°C) – A105  
3750psig@100°F (258bar@38°C) – F22  
Maximum cold hydrostatic test pressure: 5575psig (384bar) – A105  
5625psig (388bar) – F22

(1) Also available in: F22, max temp. 1050°F (565°C).

(2) Permissible, but not recommended for prolonged use above 800°F (426°C).

(3) Product will operate throughout entire pressure range, however selection closest to the Maximum operating pressure is recommended for maximum efficiency.

Clearance for strainer removal:  
N675/1500; 5/8 in (140 mm) min.

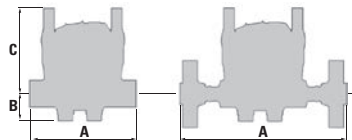

## DIMENSIONS AND WEIGHTS

SIZE NPS/DN			A FACE TO FACE			B CENTER TO BOTTOM	C CENTER TO TOP	WEIGHT lb/kg		
			SCR/SW	BW	FLG			SCR/SW	BW	FLG
1/2	3/4	1	7 1/4	13 1/4	11 1/4	2	4 1/2	24	26	37
15	20	25	184	337	286	51	115	11	12	17

## CONDENSATE CAPACITY

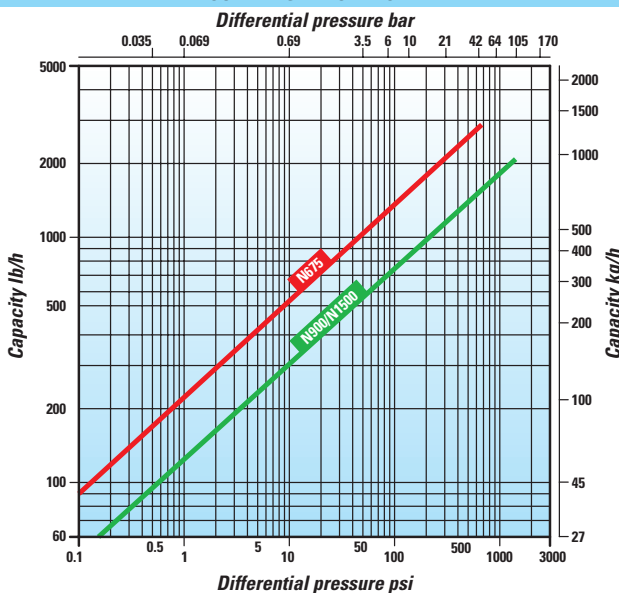

The performance graph indicates the continuous discharge capacities of condensate per hour at various pressure differentials across the trap.

## PRESSURE / TEMPERATURE LIMITS

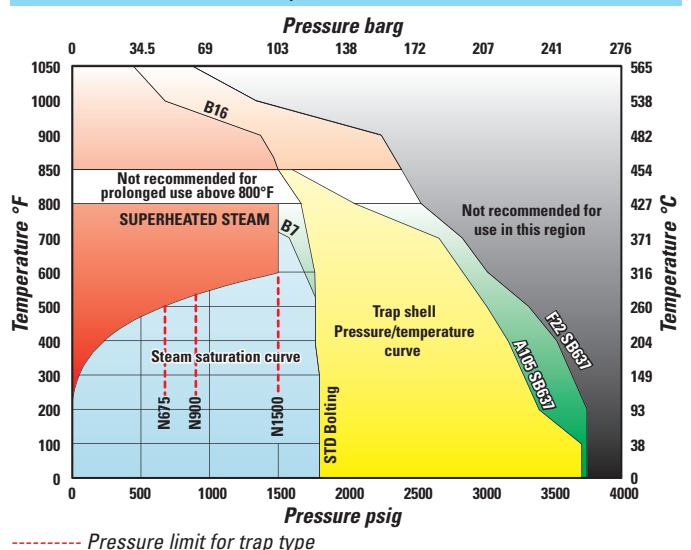

# VELAN FORGED HP/HT N2500-2600 STEAM TRAPS

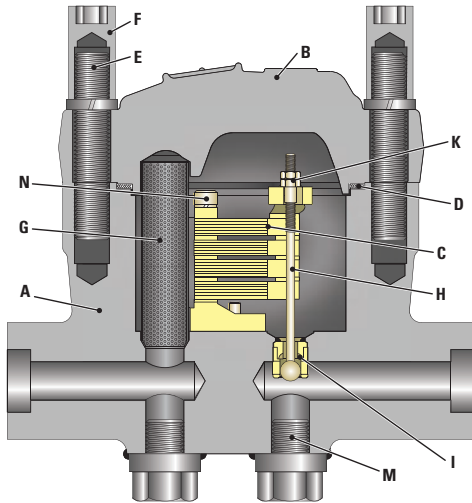

## STANDARD MATERIALS

PART	MATERIALS	
A	Body	Forged alloy steel F22, F91
B	Cover	Same as body material
C	Bimetal element	Truflex GB-14
D	Cover gasket	SS 321 spiral wound with graphite filler
E	Cover stud <sup>(1)</sup>	Chrome moly. alloy
F	Cover nut <sup>(1)</sup>	Carbon steel, stainless steel
G	Strainer	Stainless steel
H	Stem and ball	SS, ball valve 58Rc
I	Seat	SS hardfaced CoCr alloy
J	Plug gasket	SS 321 spiral wound with graphite filler
K	Adjusting nut and locknut	Stainless steel
L	Strainer blow down plug	Same as body material
M	Test plug	Same as body material
N	Fixing screw and washer	Stainless steel

## APPLICATIONS

Boiler headers, steam mains and branch lines.

## CONNECTIONS

- Screwed
- Socket-weld
- Butt-weld
- Flanged

## Type N2500/2600

(1) Durahete 1055 (F22), Nimonic 80A (F91), SB637 bolting for ANSI/ASME class 2500 shell.

## ENGINEERING DATA

PRESSURE RANGE (1) psig/barg	PMO psig/barg	MATERIAL	MAX TEMP °F/°C	ORIFICE in/mm	MAX CAPACITY lb/hr/kg/hr
500-2500 (34.5-172)	2500 (172)	F22	1050 565	5/16 8	4,800 2,182
500-2600 (34.5-179)	2600 (179)	F91	1100 593		4,900 2,227

(1) Consult works for operating pressure below 500psig (34.5 barg).

### Standard bolting: DURAHETE 1055 – F22, NIMONIC 80A – F91

Maximum design condition: ANSI/ASME Class 1500  
 PMA = Maximum allowable pressure: 3750psig@100°F (259bar@38°C)  
 TMA = Maximum allowable temperature: 1050°F (565°C) – F22  
 1100°F (593°C) – F91  
 Maximum cold hydrostatic test pressure: 5625psig (388bar)  
 TMO = Maximum operating temperature = TMA  
 PMO = Maximum operating pressure: (See Engineering data table)

### Special bolting: SB637

Maximum design condition: ANSI/ASME 2500  
 PMA = Maximum allowable pressure: 6250psig@100°F (431bar@38°C)  
 Maximum cold hydrostatic test pressure: 9375psig (647bar)

Clearance for strainer removal:  
N2500/2600; 15 in (381 mm) min.

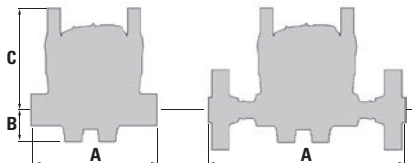

## DIMENSIONS AND WEIGHTS

SIZE NPS/DN	A FACE TO FACE			B CENTER TO BOTTOM	C CENTER TO TOP	WEIGHT lb/kg		
	SW	BW	FLG			SW	BW	FLG
1/2 15	10 254	16 406	15 1/2 349	2 5/8 67	8 1/8 206	80 36	83 38	105 48

## CONDENSATE CAPACITY

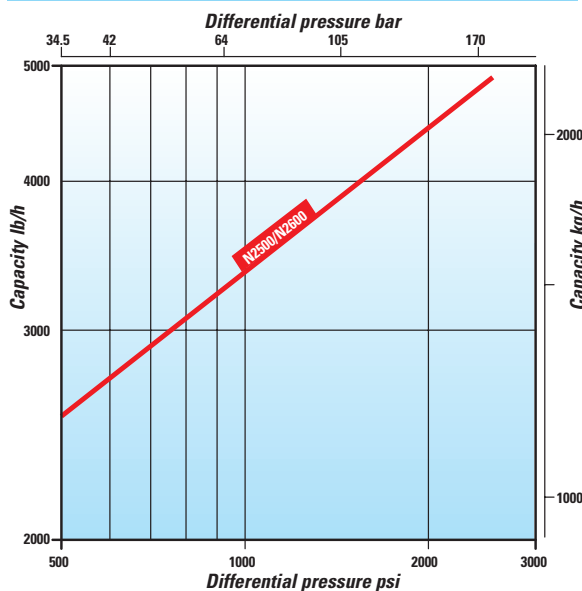

Maximum cold water capacity x 3.5

The performance graph indicates the continuous discharge capacities of condensate per hour at various pressure differentials across the trap.

## PRESSURE / TEMPERATURE LIMITS

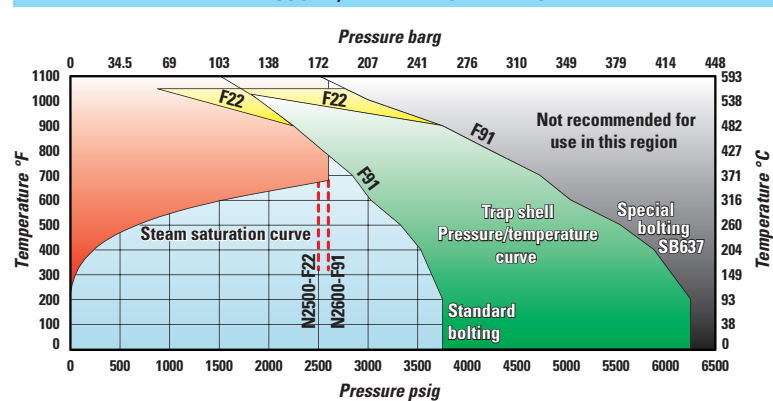

----- Pressure limit for trap type



# VELAN FORGED HP/HT N4000 STEAM TRAPS

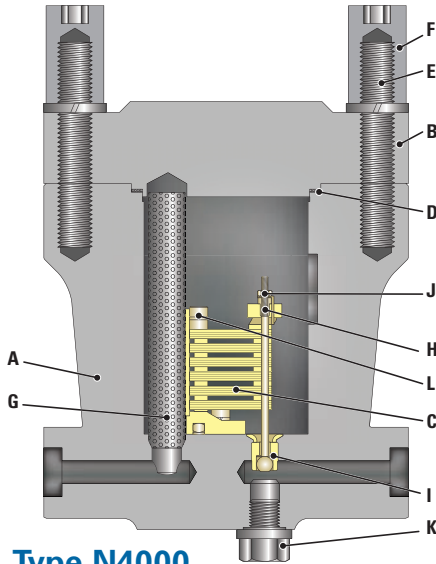

Type N4000

## STANDARD MATERIALS

PART	MATERIALS	
A	Body	Forged alloy steel F91
B	Cover	Same as body material
C	Bimetal element	Truflex GB-14
D	Cover gasket	SS 321 spiral wound with graphite filler
E	Cover stud	Nickle chrome alloy
F	Cover nut	Nickle chrome alloy
G	Strainer	Stainless steel
H	Stem and ball	SS, ball valve 58Rc
I	Seat	SS hardfaced CoCr alloy
J	Adjusting nut and locknut	Stainless steel
K	Test plug	Same as body material
L	Fixing screw and washer	Stainless steel

## APPLICATIONS

Boiler headers, steam mains and branch lines.

## CONNECTIONS

- Socket-weld
- Butt-weld

## ENGINEERING DATA

PRESSURE RANGE psig/barg	PMO psig/barg	MATERIAL	MAX TEMP °F/°C	ORIFICE in/mm	MAX CAPACITY lb/hr/kg/hr
500-4000 (34.5-276)	4000 (276)	F91	1100 593	5/16 8	4,900 4,900

Maximum body design condition: ANSI/ASME Class 4500  
 PMA = Maximum allowable pressure: 11250psig@100°F (776bar@38°C)  
 TMA = Maximum allowable temperature: 1100°F (593°C)  
 Maximum cold hydrostatic test pressure: 16875psig (1164bar)  
 TMO = Maximum operating temperature = 1050°F (565°C)  
 PMO = Maximum operating pressure: (See Engineering data table)

Clearance for strainer removal:  
N4000: 18 in (457 mm) min.

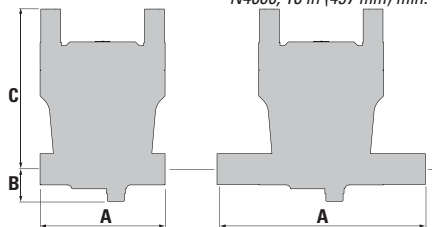

## DIMENSIONS AND WEIGHTS

SIZE NPS/DN	A FACE TO FACE		B CENTER TO BOTTOM	C CENTER TO TOP	WEIGHT lb/kg	
	SW	BW			SW	BW
1/2 15	10 254	16 406	2 5/8 67	14 356	120 55	125 57

## CONDENSATE CAPACITY

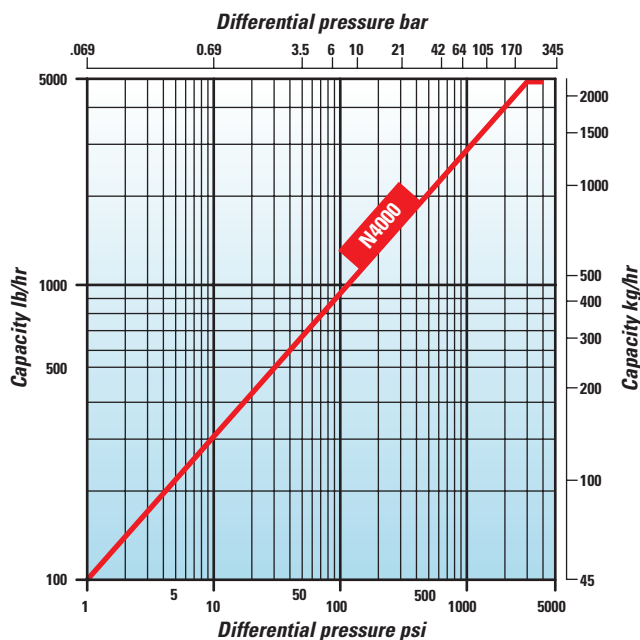

The performance graph indicates the continuous discharge capacities of condensate per hour at various pressure differentials across the trap.

## SHELL PRESSURE/TEMP LIMIT

TEMPERATURE °F (°C)	PRESSURE psig (barg)	TEMPERATURE °F (°C)	PRESSURE psig (barg)
100 (38)	11,250 (775.5)	750 (399)	7,970 (549.5)
200 (93)	11,250 (775.5)	800 (427)	7,610 (524.5)
300 (149)	10,925 (753)	850 (454)	7,305 (503.5)
400 (204)	10,585 (730)	900 (482)	6,740 (465)
500 (260)	9,965 (687)	950 (510)	5,795 (399.5)
600 (315)	9,070 (625)	1000 (538)	5,450 (376)
650 (343)	8,825 (608.5)	1050 (565)	5,400 (372)
700 (371)	8,515 (587)	1100 (593)	4,525 (312)

Maximum cold water capacity x 3.5

# VELAN HERMETICALLY SEALED STEAM TRAP

## HERMETICALLY SEALED UNIT ON TYPE Q250 AND UST

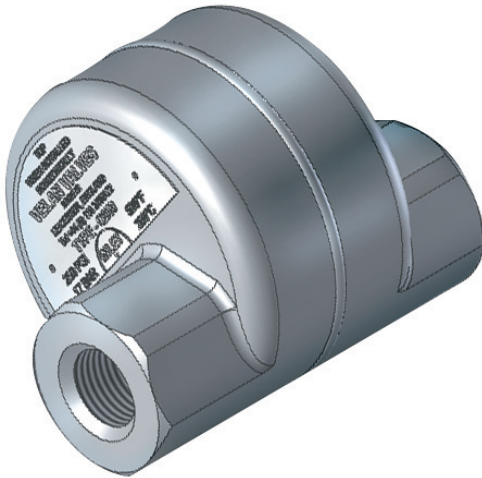

### HERMETICALLY SEALED UNIT

The hermetically sealed body is seal welded and contains all operating parts.



Type Q250

Type UST

### COMMON DESIGN FEATURES

- **Positive closing**  
The bimetallic element is a function of the saturated steam curve (pages 4 and 5) and its sensitivity to the temperature change assures an immediate reaction to both steam and condensate for the entire pressure range. At saturated temperature the valve is closed.
- **All-position installation**  
Simplifies piping layout for easy plant standardization.
- **Self-aligning precision ball valve**  
Single free-floating stainless steel hardened Rc 58 min. ball valve.
- **Air venting: Good discharge capacity**  
Air and cold condensate is discharged through a full orifice efficiently ensuring fast warm-up of equipment.
- **Check valve operation**  
The main valve acts as a check valve preventing back flow.
- **Positive condensate drainage** for process work.
- **Guaranteed against water hammer**  
The downstream valve acts as a release valve on the excess water pressure without damage to internal parts.
- **Seat CoCr alloy hardfaced**  
Increases resistance to the high degree of wear through velocity of flow, dirt, and scale.

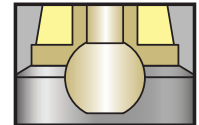

### TYPE Q250 DESIGN FEATURES

- **Freeze-proof installation**  
Velan traps do not require a reservoir of priming water in the body to operate. When installed vertically with inlet on top, they drain completely when cold, and are freeze-proof without insulation.

### TYPE UST DESIGN FEATURES

- **Integral strainer**  
An integral stainless steel strainer protects the trap operating mechanism from damage by dirt or scale. No extra fittings or installation costs are required. Free strainer area 26%. Perforation is 0.031" (0.8mm).
- **Compatibility**  
Compatible with most other manufacturers trap modules.
- **Easy removal**  
Steam trap can be removed and replaced in minutes by undoing 2-bolts and without having to disconnect any piping.
- NPT blow down plug
- Velan connectors are available separately with screwed and socket-weld connections.
- All position installation (swivel 360°).

# VELAN HERMETICALLY SEALED Q250 STEAM TRAP

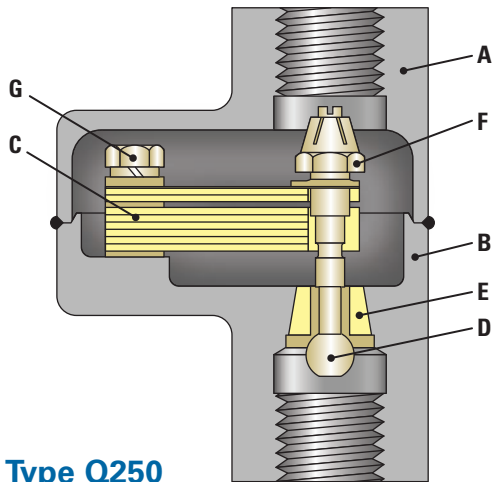

Type Q250

## STANDARD MATERIALS

PART		MATERIALS
A	Inlet shell	Stainless steel CF8M
B	Outlet shell	Stainless steel CF8M
C	Bimetal element	Truflex GB-14
D	Stem and ball	SS, ball valve 58Rc min.
E	Seat	CoCr alloy
F	Self locking adjustable nut	Stainless steel
G	Fixing screw	Stainless steel

## APPLICATIONS

Boiler headers, steam mains, branch lines, tracer lines, sterilizers and finned radiation.

## CONNECTIONS:

- Screwed
- Socket-weld

## SIMPLE PRINCIPLE OF OPERATION

A single free-floating ball valve:

- Vents air
- Discharges condensate
- Traps steam
- Acts as a check valve

## ENGINEERING DATA

PRESSURE RANGE psig/barg	PMO psig/barg	MATERIAL	MAX TEMP °F/°C	ORIFICE in/mm	MAX CAPACITY lb/hr/kg/hr
0-250 (0-17)	250 (17)	SS CF8M	500 260	3/8 9.5	2,700 1,227

Maximum design condition: ANSI/ASME 300  
 PMA = Maximum allowable pressure: 720psig@100°F (49bar@38°C)  
 TMA = Maximum allowable temperature: 500°F (260°C)  
 Maximum cold hydrostatic test pressure: 1100psig (75bar)  
 TMO = Maximum operating temperature = TMA  
 PMO = Maximum operating pressure: (See Engineering data table)

## DIMENSIONS AND WEIGHTS

SIZE NPS/DN	A FACE TO FACE	B CENTER TO BOTTOM	C CENTER TO TOP	WEIGHT lb/kg
1/2 15	4	3/4	2 1/2	3 1/2
3/4 20	102	19	64	1.5

## CONDENSATE CAPACITY

The performance graph indicates the continuous discharge capacities of condensate per hour at various pressure differentials across the trap.

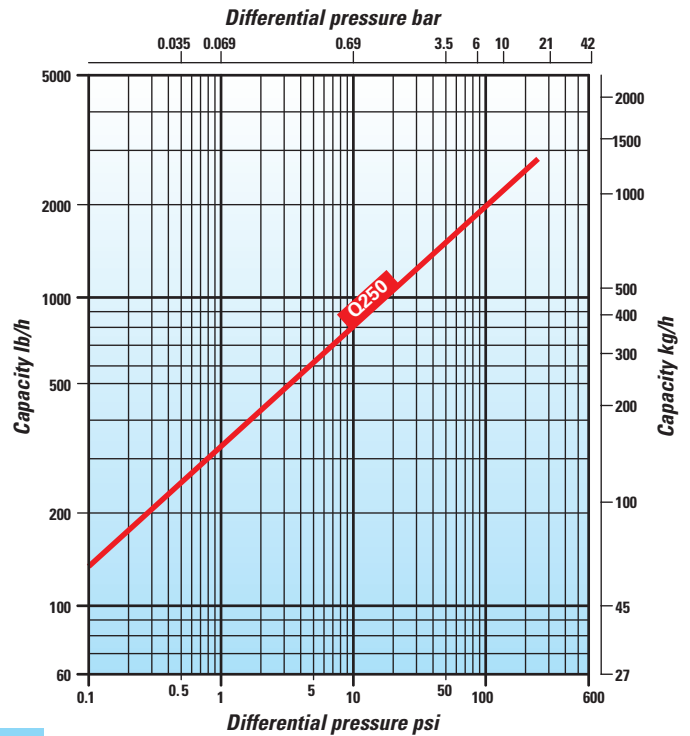

Maximum cold water capacity x 3.5

## PRESSURE / TEMPERATURE LIMITS

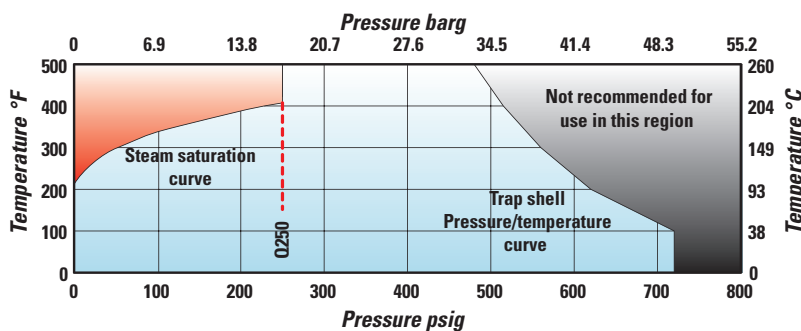

----- Pressure limit for trap type

# VELAN HERMETICALLY SEALED UST STEAM TRAP

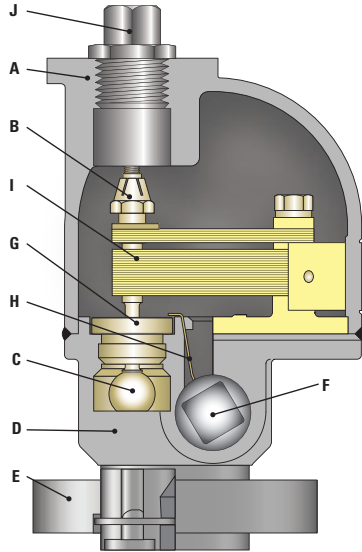

Type  
UST

## STANDARD MATERIALS

PART	MATERIALS	
A	Cover	Stainless steel CF8M
B	Self locking adjustable nut	Stainless steel
C	Stem and ball	SS, ball valve 58Rc min.
D	Body	Stainless steel CF8M
E	Flange	Stainless steel F316
F	Blowdown plug	Carbon steel electroplated
G	Seat	Stainless steel 316 hardfaced with CoCr alloy
H	Strainer	Stainless steel 304
I	Bimetal element	Truflex GB-14
J	Plug	Carbon steel electroplated

## APPLICATIONS

Boiler headers, steam mains, branch lines, tracer lines, sterilizers and finned radiation.

## CONNECTIONS:

- Screwed
- Socket-weld

## SIMPLE PRINCIPLE OF OPERATION

A single free-floating ball valve:

- Vents air
- Traps steam
- Discharges condensate
- Acts as a check valve

## ENGINEERING DATA

PRESSURE RANGE (1) psig/barg	PMO psig/barg	MATERIAL	MAX TEMP °F/°C	ORIFICE in/mm	MAX CAPACITY lb/hr/kg/hr
0-300 (0-21)	300 (21)	S/S CF8M	600 315	5/16 8	690 315
0-450 (0-31)	450 (31)			1/4 6.4	400 180

(1) Product will operate throughout entire pressure range, however selection closest to the Maximum operating pressure is recommended for maximum efficiency.

Maximum design condition: ANSI/ASME 300  
 PMA = Maximum allowable pressure: 720psig@100°F (50bar@38°C)  
 TMA = Maximum allowable temperature: 600°F (315°C) (see note)  
 Maximum cold hydrostatic test pressure: 1100psig (75bar)  
 TMO = Maximum operating temperature = TMA  
 PMO = Maximum operating pressure: (See Engineering data table)

## CONDENSATE CAPACITY

The performance graph indicates the continuous discharge capacities of condensate per hour at various pressure differentials across the trap.

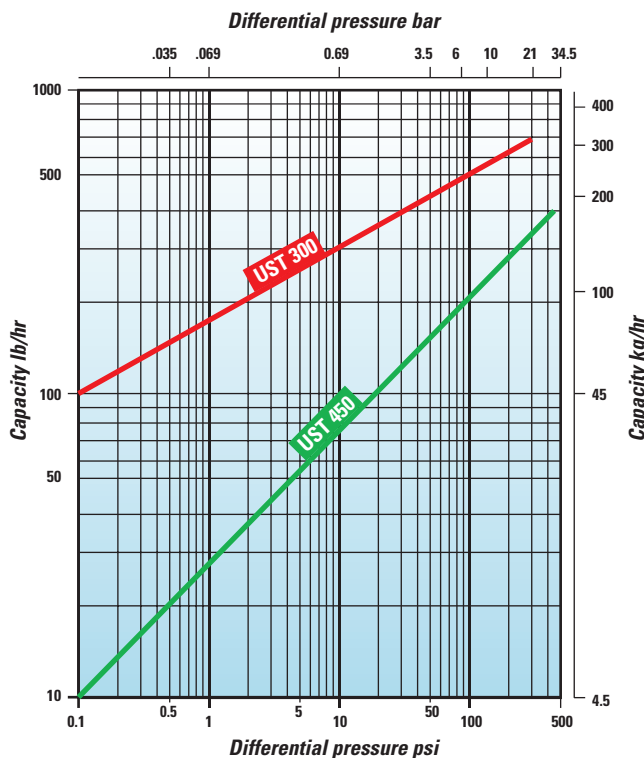

Maximum cold water capacity x 3.5

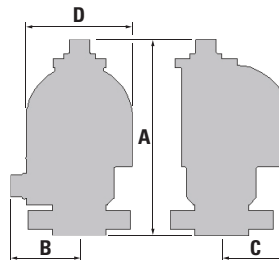

## DIMENSIONS AND WEIGHTS

A OVERALL LENGTH	B CENTER TO B/DOWN PLUG	C CENTER TO TOP OF COVER	D COVER DIAMETER	WEIGHT lb/kg
5 1/8 130	1 7/8 48	1 3/4 45	2 3/4 70	3 1/2 1.5

## PRESSURE / TEMPERATURE LIMITS

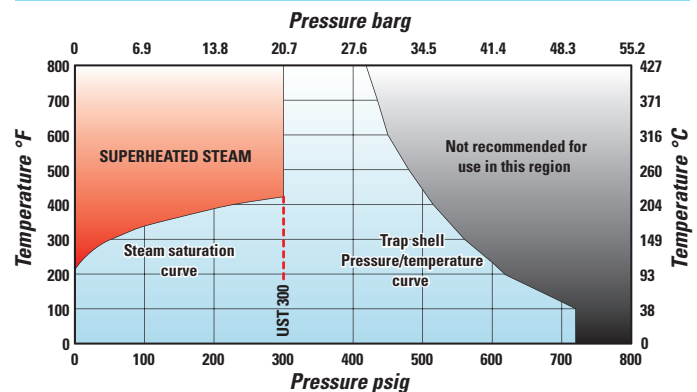

----- Pressure limit for trap type

# VELAN CONNECTORS

## VELAN CONNECTORS FOR HERMETICALLY SEALED UNIVERSAL STEAM TRAP

Velan connectors are designed to be used with swivel connector steam traps.

The connector can be installed horizontally or vertically into the pipeline. The steam trap is attached to the connector by means of two hexagon screws and can be rotated 360 degrees to ensure the trap is in correct orientation.

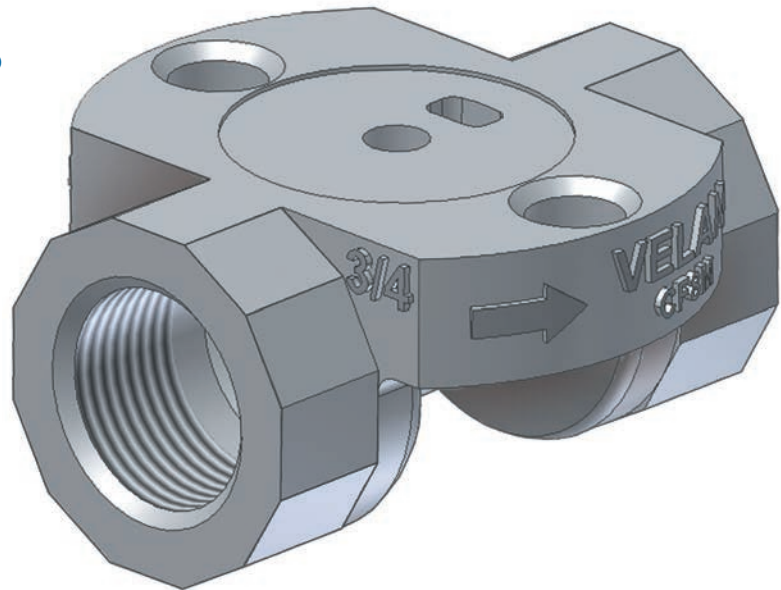

### CONNECTIONS

- Screwed
- Socket-weld

### ENGINEERING DATA

PRESSURE RANGE psig / barg	MATERIAL	MAX TEMP <sup>(1)</sup> °F / °C
0-450 0-31	SS CF8M	600 315

(1) Consult works if the expected service temperature will be >500°F (260°C) as the ferrite level has to be controlled.

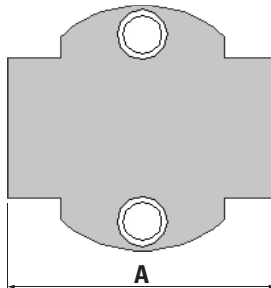

### DIMENSIONS AND WEIGHTS

SIZE NPS / DN	A FACE TO FACE	WEIGHT lb / kg
1/2 15	2 7/16 62	1.1 0.5
3/4 20	2 7/8 73	1.2 0.55
1 25	3 1/2 89	1.9 0.86

Illustration showing a complete assembly of universal steam trap connector.

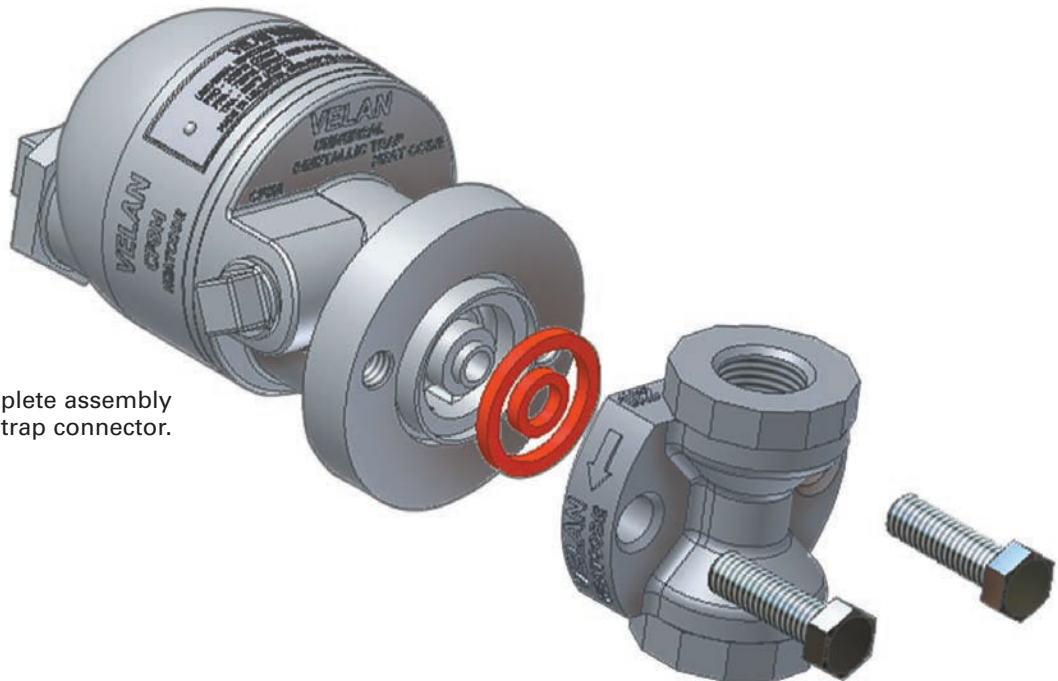

# VELAN HIGH CAPACITY PISTON OPERATED STEAM TRAP

Type  
SP



Type  
SPF



## COMMON DESIGN FEATURES

- Piston cage unit**  
 The advanced piston cage unit design combines a liner, piston, main seat and main valve into one factory-tested assembly to ensure precise alignment and simple maintenance. In the SPF Type there is also a bimetallic cage unit.
- Seats CoCr alloy hardfaced**  
 The main and pilot valve seats are CoCr alloy hardfaced to increase their resistance to the high degree of wear through velocity of flow, dirt and scale.
- All in one construction unit**  
 Air vent, main valve, check valve, strainer and temperature controller are a single unit, ensuring perfect alignment and ease of maintenance.

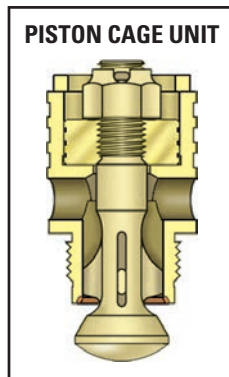

- Positive closing**  
 As steam contacts the bimetal element, the pull closes the pilot valve, reducing the pressure on the piston. Line pressure below the main valve closes the valve tightly on the seat (see page 7).
- Positive condensate drainage** for process work.
- Check valve operation**  
 The main valve acts as a check valve preventing back flow.
- Temperature controller**  
 controls and adjusts the discharge temperature of condensate which can be calibrated using a special thermometer (see page 45).

## SP DESIGN FEATURES

- Integral strainer**  
 An Integral stainless steel strainer protects the trap operating mechanism from damage by dirt or scale.
- No extra fittings or installation costs are required. Free strainer area minimum 5 to 1. Perforation is 0.031" (0.8 mm).

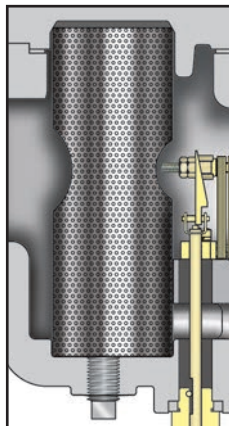

## TYPE SPF DESIGN FEATURES

- SPF only:** Can include a "Y" type strainer in line to protect trap.

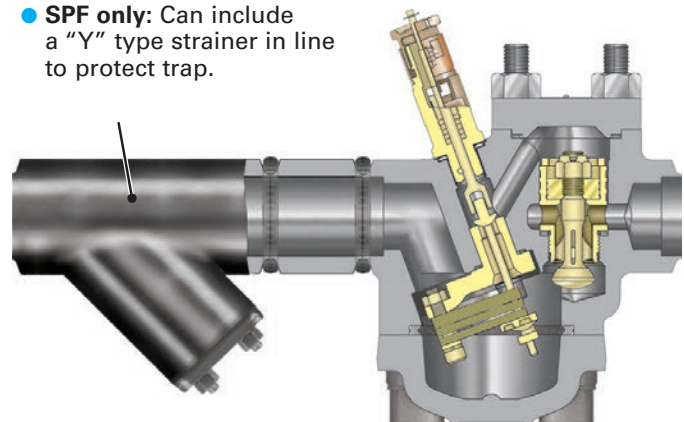

# VELAN HIGH CAPACITY PISTON OPERATED STEAM TRAP

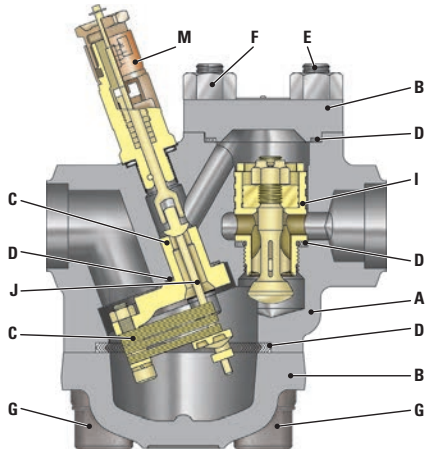

## STANDARD MATERIALS

PART	MATERIALS	
A	Body	Forged carbon steel A105
B	Cover	Same as body material
C	Bimetal element	Truflex GB-14
D	Gasket	SS 321 spiral wound with graphite filler
E	Cover stud	Chrome moly. alloy B7
F	Cover nut	Carbon steel 2H
G	Cap screw	Chrome moly alloy
I	Piston cage unit	Stainless steel
J	Pilot valve	Stainless steel, ball 58Rc min.
M	Temperature controller	Stainless steel

## APPLICATIONS

Boiler headers, steam mains, branch lines, steam separators, oil storage tank coils, purifiers, de-superheater drains, reboilers, feed water heaters, heat exchangers and cold reheat drains.

## CONNECTIONS

- Screwed
- Socket-weld
- Butt-weld
- Flanged

## Type SPF0-7 (A105)

### ENGINEERING DATA

TYPE	PRESSURE RANGE (2) psig/barg	PMO psig/barg	MATERIAL	MAX TEMP °F/°C	ORIFICE in/mm	MAX CAPACITY lb/hr/kg/hr
SPF0	10-200 0.69-14	200 14	A105	850 <sup>(1)</sup> 454	7/8 22	17,000 7,727
SPF1	10-350 0.69-24	350 24				19,000 8,636
SPF2	10-600 0.69-42	600 42				22,000 10,000
SPF3	10-1500 0.69-103	1500 103				27,000 12,273

TYPE	PRESSURE RANGE (2) psig/barg	PMO psig/barg	MATERIAL	MAX TEMP °F/°C	ORIFICE in/mm	MAX CAPACITY lb/hr/kg/hr
SPF4	10-200 0.69-14	200 14	A105	850 <sup>(1)</sup> 454	1 3/8 35	38,000 17,272
SPF5	10-350 0.69-24	350 24				43,000 19,545
SPF6	10-600 0.69-42	600 42				49,000 22,272
SPF7	10-1500 0.69-103	1500 103				63,000 28,636

(1) Permissible, but not recommended for prolonged use above 800°F (427°C).

(2) Product will operate throughout entire pressure range, however selection closest to the Maximum operating pressure is recommended for maximum efficiency.

PMA: Maximum allowable pressure: 3000psig@100°F (207bar@38°C)

TMA: Maximum allowable temperature: 800°F (427°C)

Maximum cold hydrostatic test pressure: 4500psig (310bar)

TMO = Maximum operating temperature = TMA

PMO: Maximum operating pressure: (see Engineering data table)

## DIMENSIONS AND WEIGHTS

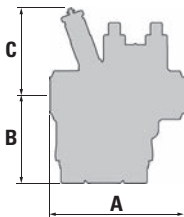

TYPE	SIZE NPS/DN		A FACE TO FACE								B CENTER TO BOTTOM		C CENTER TO TOP		WEIGHT lb/kg			
			SCR/ SW	BW	FLANGED				SCR/ SW	BW					FLANGED			
					SPF0/4	SPF1/5	SPF2/6	SPF3/7							SPF0/4	SPF1/5	SPF2/6	SPF3/7
SPF 0,1,2,3	1 25	1 1/2 40	7 3/4 197	13 3/4 349	10 3/4 273	11 279	11 279	12 3/4 324	4 7/8 124	5 3/16 132	35 16	39 18	48 22	53 24	56 25	64 29		
SPF 4,5,6,7	1 1/2 40	2 50	8 3/4 222	14 3/4 375	12 305	12 305	12 305	14 1/4 362	5 1/8 130	5 1/2 140	50 23	55 25	67 30	69 31	81 37	100 45		

## CONDENSATE CAPACITY

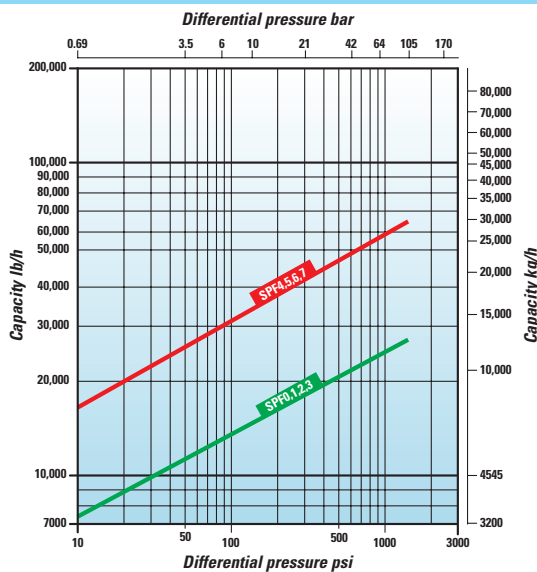

Maximum cold water capacity x 3.5

The performance graph indicates the continuous discharge capacities of condensate per hour at various pressure differentials across the trap.

## PRESSURE / TEMPERATURE LIMITS

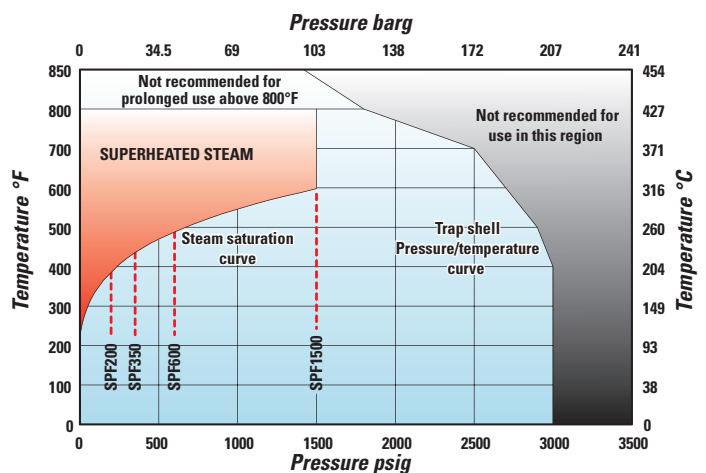

----- Pressure limit for trap type

# VELAN HIGH CAPACITY PISTON OPERATED STEAM TRAP

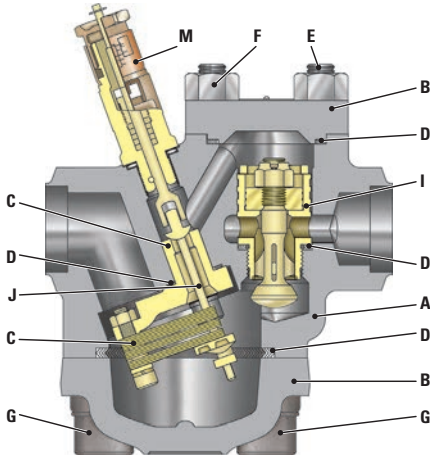

## STANDARD MATERIALS

PART	MATERIALS	
A	Body	Forged alloy steel F22
B	Cover	Same as body material
C	Bimetal element	Truflex GB-14
D	Gasket	SS 321 spiral wound with graphite filler
E	Cover stud	Chrome moly. alloy B16
F	Cover nut	Carbon or stainless steel
G	Cap screw	Chrome moly. alloy
I	Piston cage unit	Stainless steel
J	Pilot valve	Stainless steel, ball 58Rc min.
M	Temp controller	Stainless steel

## APPLICATIONS

Boiler headers, steam mains, branch lines, steam separators, oil storage tank coils, purifiers, de-superheater drains, reboilers, feed water heaters, heat exchangers and cold reheat drains.

## Type SPF0-7 (F22)

## CONNECTIONS

- Screwed
- Socket-weld
- Butt-weld
- Flanged

## ENGINEERING DATA

TYPE	PRESSURE RANGE <sup>(1)</sup> psig/barg	PMO psig / barg	MATERIAL	MAX TEMP °F/°C	ORIFICE in/mm	MAX CAPACITY lb/hr/kg/hr
SPF0	10-200 0.69-14	200 14	F22	1050 565	7/8 22	17,000 7,727
SPF1	10-350 0.69-24	350 24				19,000 8,636
SPF2	10-600 0.69-42	600 42				22,000 10,000
SPF3	10-1500 0.69-103	1500 103				27,000
						12,273

TYPE	PRESSURE RANGE <sup>(1)</sup> psig/barg	PMO psig/barg	MATERIAL	MAX TEMP °F/°C	ORIFICE in/mm	MAX CAPACITY lb/hr/kg/hr
SPF4	10-200 0.69-14	200 14	F22	1050 565	1 3/8 35	38,000 17,272
SPF5	10-350 0.69-24	350 24				43,000 19,545
SPF6	10-600 0.69-42	600 42				49,000 22,272
SPF7	10-1500 0.69-103	1500 103				63,000
						28,636

(1) Product will operate throughout entire pressure range, however selection closest to the Maximum operating pressure is recommended for maximum efficiency.

PMA = Maximum allowable pressure: 2600psig@100°F (179bar@38°C)  
 TMA = Maximum allowable temperature: 1050 F (565°C)  
 Maximum cold hydrostatic test pressure: 3900psig (269bar)  
 TMO = Maximum operating temperature = TMA  
 PMO = Maximum operating pressure: (see Engineering data table)

## DIMENSIONS AND WEIGHTS

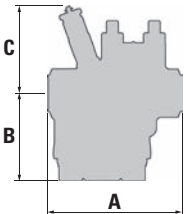

TYPE	SIZE NPS/DN	A FACE TO FACE								B CENTER TO BOTTOM	C CENTER TO TOP	WEIGHT lb/kg							
		SCR/SW	BW	FLANGED				SCR/SW	BW			FLANGED							
				SPF0/4	SPF1/5	SPF2/6	SPF3/7					SPF0/4	SPF1/5	SPF2/6	SPF3/7				
SPF 0,1,2,3	1	1 1/2	7 3/4	13 3/4	10 3/4	11	11	12 3/4	4 7/8	5 3/16	35	39	48	53	56	64			
	25	40	197	349	273	279	279	324	124	132	16	18	22	24	25	29			
SPF 4,5,6,7	1 1/2	2	8 3/4	14 3/4	12	12	12	14 1/4	5 1/8	5 1/2	50	55	67	69	81	100			
	40	50	222	375	305	305	305	362	130	140	23	25	30	31	37	45			

## CONDENSATE CAPACITY

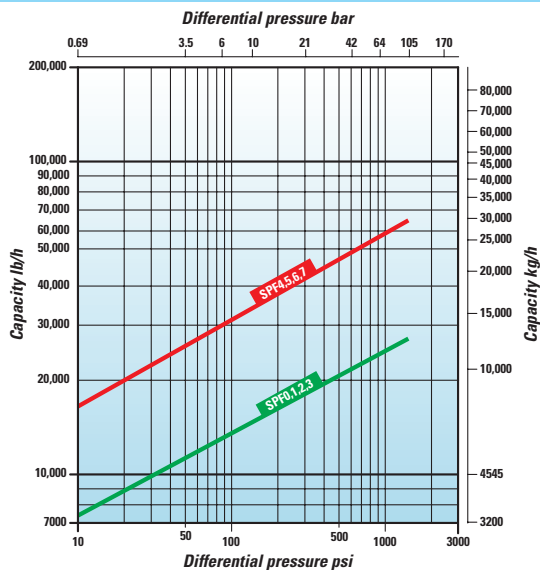

The performance graph indicates the continuous discharge capacities of condensate per hour at various pressure differentials across the trap.

## PRESSURE / TEMPERATURE LIMITS

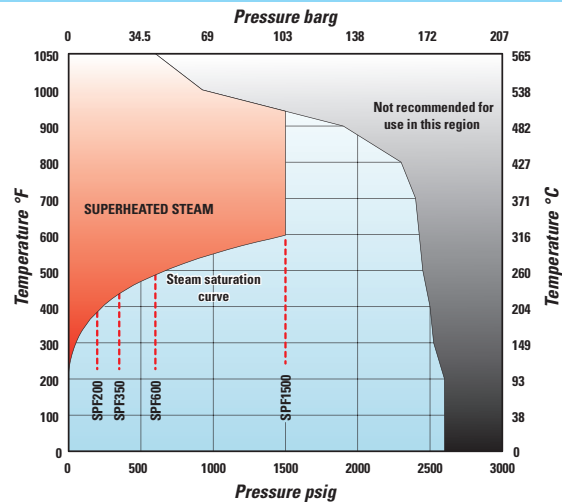



# VELAN HIGH CAPACITY PISTON OPERATED STEAM TRAP

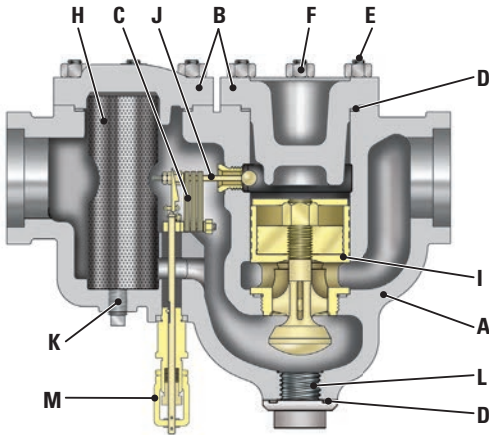

## STANDARD MATERIALS

PART	MATERIALS
A	Body Cast steel WCB
B	Cover Same as body material
C	Bimetal element Truflex GB-14
D	Gasket SS 321 spiral wound with graphite filler
E	Cover stud Chrome moly. alloy B7
F	Cover nut Carbon steel 2H
H	Strainer Stainless steel
I	Piston cage unit Stainless steel
J	Pilot valve Stainless steel, ball 58Rc min.
K	Blowdown plug Carbon steel
L	Bottom plug Stainless steel
M	Temp controller Stainless steel

## APPLICATIONS

Boiler headers, steam mains, branch lines, steam separators, oil storage tank coils, purifiers, de-superheater drains, reboilers, feed water heaters, heat exchangers and high-pressure/temperature applications with high condensate discharge rates.

## Type SP6, 7, AND 8 (cast)

## CONNECTIONS

- Screwed
- Socket-weld
- Butt-weld
- Flanged

## ENGINEERING DATA

PRESSURE RANGE <sup>(2)</sup> psig/barg	PMO psig/barg	MATERIAL	MAX TEMP °F/°C	ORIFICE in/mm	MAX CAPACITY lb/hr/kg/hr
10-200 (0.69-14)	200 (14)	WCB	850 <sup>(1)</sup> 454	2 51	90,000 40,909
10-600 (0.69-42)	600 (42)				130,000 59,090
10-1500 (0.69-103)	1500 (103)				160,000 72,727

### SP 6 AND 7

PMA = Maximum allowable pressure: 1250psig@100°F (86bar@38°C)  
Maximum cold hydrostatic test pressure: 1875psig (129bar)

### SP 8

PMA = Maximum allowable pressure: 2000psig@100°F (138bar@38°C)  
Maximum cold hydrostatic test pressure: 3000psig (207bar)  
TMA = Maximum allowable temperature: 800°F (427°C)  
TMO = Maximum operating temperature = TMA  
PMO = Maximum operating pressure: (see Engineering data table)

(1) Permissible, but not recommended for prolonged use above 800°F (427°C).

(2) Product will operate throughout entire pressure range, however selection closest to the Maximum operating pressure is recommended for maximum efficiency.

## DIMENSIONS AND WEIGHTS

Clearance for Strainer Removal:  
SP 12 in (305 mm) min.

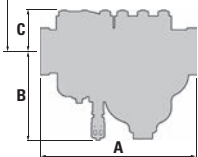

TYPE	SIZE NPS/DN	A FACE TO FACE					B CENTER TO BOTTOM	C CENTER TO TOP	WEIGHT lb/kg					
		SCR/ SW	BW	FLANGED					SCR/SW		FLANGED			
				SP6	SP7	SP8			SP6	SP7 & SP8	SP6	SP7 & SP8		
SP 6,7,8	2	15	21	18	19	22	9 1/8 232	4 1/4 108	115	120	118	123	139	170
	50										54	56	63	77
	2 1/2	16	22	457	483	559	9 1/8 232	4 1/4 108	115	120	120	125	151	192
	65										55	57	69	87
3	80	406	559	457	483	559	9 1/8 232	4 1/4 108	115	120	122	127	155	216
											80	56	58	70

## CONDENSATE CAPACITY

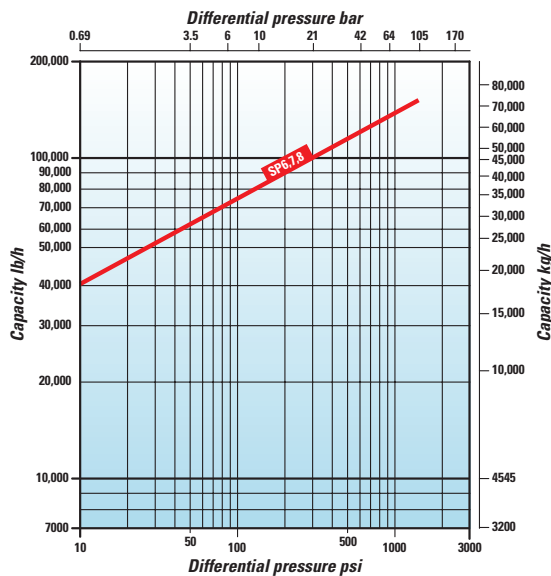

Maximum cold water capacity x 3.5

The performance graph indicates the continuous discharge capacities of condensate per hour at various pressure differentials across the trap.

## PRESSURE / TEMPERATURE LIMITS

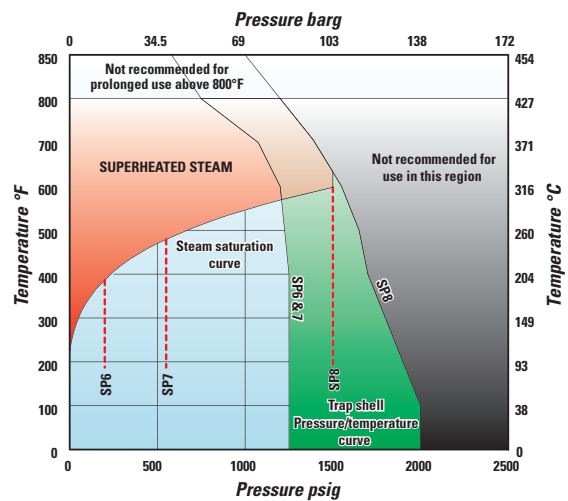

----- Pressure limit for trap type

# VELAN PIPING KING PACKAGE UNITS

## *Velan forged Piping King automatic condensate drain units a unique method in steam trap piping*

The Piping King package unit fitted with a bypass, enables the steam trap to be isolated from the system allowing routine maintenance to be carried out.

### THE UNIT CONSISTS OF:

- The unique patented universal steam trap with integral strainer and check valve
- Two high-quality bonnetless forged steel special stop check globe valves mounted on either side of the trap. The valves are connected by the bypass pipe, enabling the steam trap to be isolated while the steam flow is maintained.

Piping King units are used extensively in power stations, marine, and similar applications where continuous operation is essential during routine maintenance. (See pages 28 and 29 for details.)

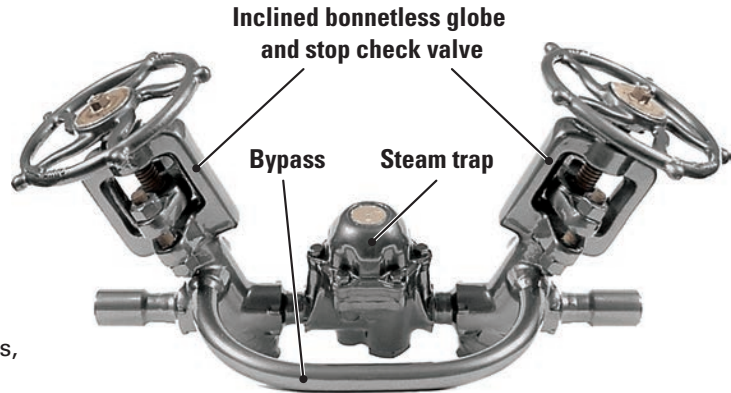

## *Velan Piping Kings provide substantial savings, in component parts and installation costs*

### CONVENTIONAL UNIT WITH BYPASS (3 VALVES) AND BUCKET TRAP

8 Hours

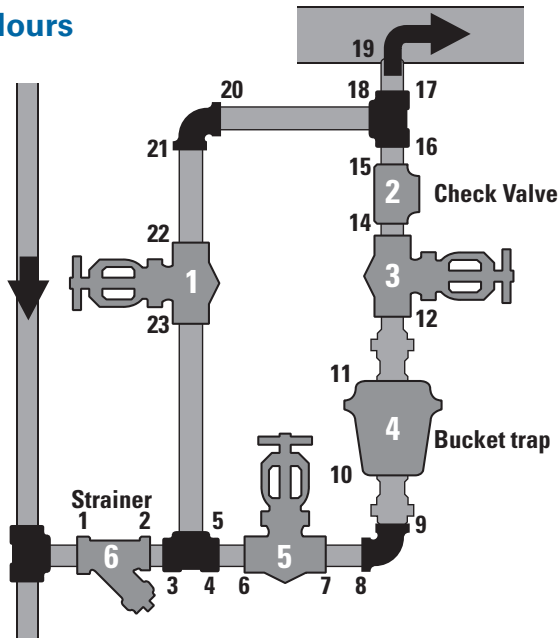

**6 Units - 23 Welds**

- |                                |                            |
|--------------------------------|----------------------------|
| 1 Steel 3/4" bucket steam trap | 23 Welded joints (6 hours) |
| 3 Forged steel valves          | 2 Elbows 3/4" (s.w.)       |
| 1 Steel strainer 3/4"          | 3 Tees 3/4" (s.w.)         |
| 1 Steel check valve 3/4"       | 2 Unions 3/4"              |

**Fitting time (2 hours)**

### VELAN PIPING KING UNIT WITH BYPASS (2 VALVES ONLY)

70 Minutes

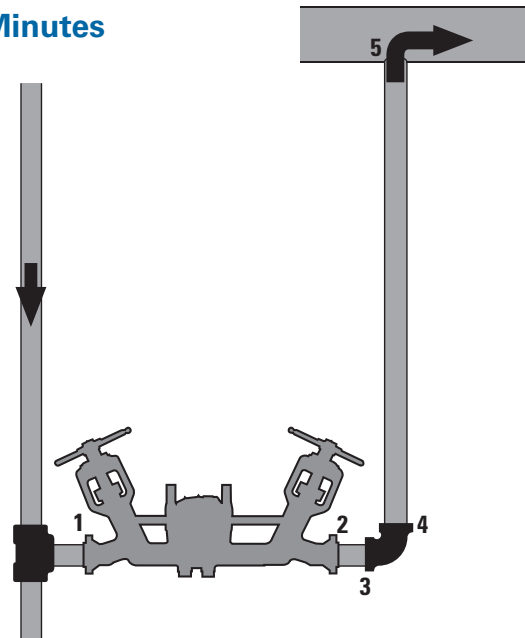

**1 Unit - 5 Welds**

- |                                     |
|-------------------------------------|
| 1 Velan Piping King 3/4" Type NV-BY |
| 5 Welded joints (1 hour)            |

**Fitting time (10 minutes)**

# HOW IT WORKS

## 1. AUTOMATIC STEAM TRAP OPERATION

Inlet valve and outlet valve both in top, closed position to provide double protection against leakage through the bypass.

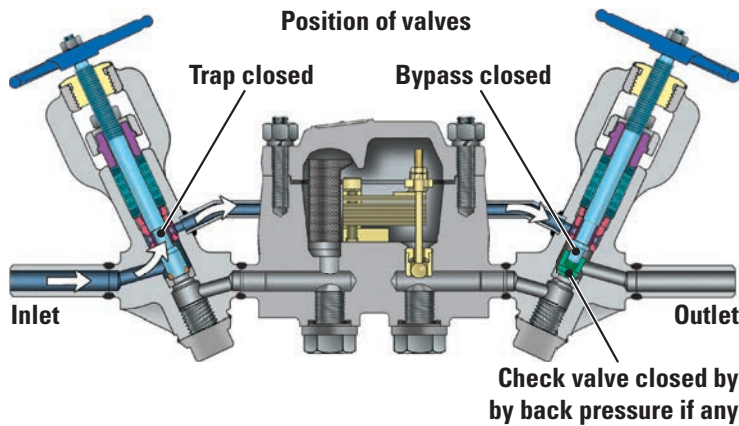
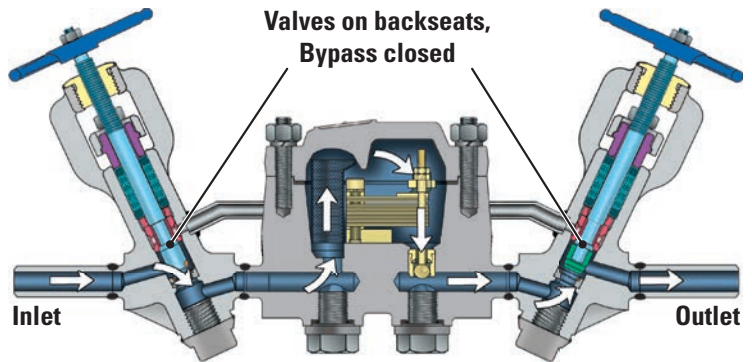

## 2. COMPLETE SHUTOFF – NO FLOW TRAP ISOLATED FOR SERVICE

Inlet valve in bottom position, outlet valve in top position. The trap is now sealed off by the inlet valve and the bypass is closed by the outlet valve. The valve is protected from back-pressure by the check valve portion of the outlet valve.

## 3. BYPASS OPEN – FULL FLOW TRAP ISOLATED FOR SERVICE PREFERRED SERVICE POSITION

Both inlet valve and outlet valves in bottom position to seal off the trap against flow and back-pressure.

Trap is isolated and ready for service.

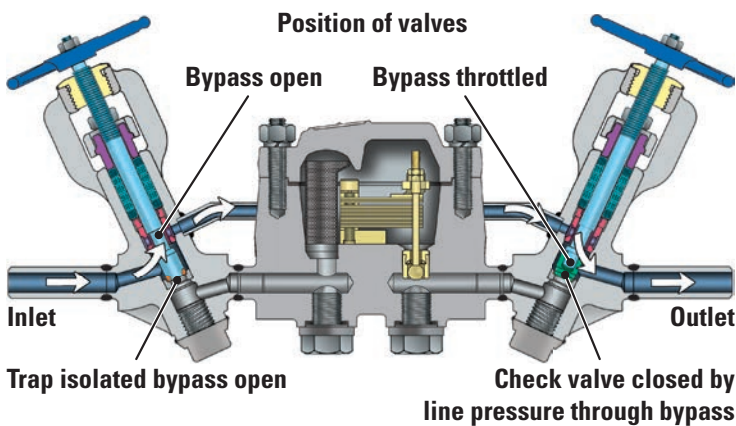
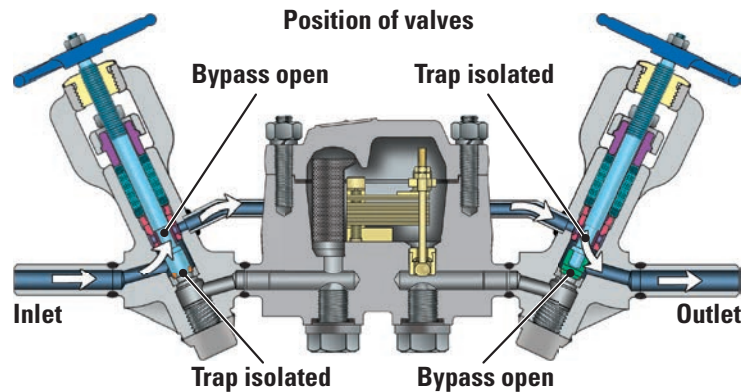

## 4. THROTTLED BYPASSING – TRAP ISOLATED FOR SERVICE

Inlet valve in bottom position, outlet valve in intermediate position. The trap is sealed off by the inlet valve and flow through the bypass is restricted by the position of the outlet valve. The floating check valve of the outlet valve protects the trap from back pressure.

# VELAN PIPING KING PACKAGE UNITS

## TS-V-BY, TSF-V-BY AND SF-V-BY

### ENGINEERING DATA

TYPE	PRESSURE RANGE <sup>(2)</sup> psig/barg	ORIFICE in/mm	MAX CAPACITY lb/h kg/h
TS-V-BY (1)	0-120 0-8	3/8 9.5	1,650 750
	0-250 0-17	5/16 8	1,500 682
	0-300 0-21	5/16 8	1,700 773
TSF-V-BY (1)	0-200 0-14	3/8 9.5	2,000 909
	0-485 0-33.5	1/4 6.5	1,400 636
SF-V-BY (1)	0-50 0-3.5	3/4 19	3,250 1,477
	0-150 0-10.4	1/2 12.7	3,250 1,477
	0-300 0-21	1/2 12.7	4,500 2,045
	0-400 0-28	3/8 9.5	3,100 1,409
	0-600 0-42	5/16 8	2,600 1,182

Material and maximum temperature:

(1) A105, max. temp. 850°F (454°C), which is permissible, but not recommended for prolonged use above 800°F (426°C).

(2) Product will operate throughout entire pressure range, however selection closest to the Maximum operating pressure is recommended for maximum efficiency.

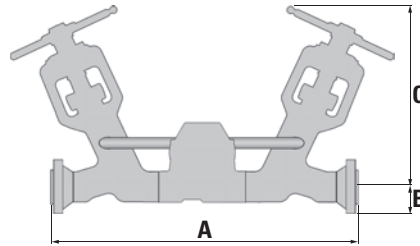

### DIMENSIONS AND WEIGHTS

TYPE	SIZE NPS/DN	A FACE TO FACE			B CENTER TO BOTTOM	C CENTER TO TOP	WEIGHT LB/KG		
		SCR/ SW	BW	FLG			SCR/ SW	BW	FLG
TS-V-BY	3/8 10								
	1/2 15	15 1/4 387	17 1/4 438	15 1/4 387	2 50	7 3/4 197	17 7.5	18 8	24 11
	3/4 20								
TSF-V-BY	1/2 15	15 5/8 397	17 5/8 448	15 5/8 397	2 50	7 3/4 197	29 13	30 14	35 16
	3/4 20								
SF-V-BY-50	1/2 15	17 3/8 441	19 3/8 492	17 1/8 435	2 1/4 57	8 9/16 217			
	3/4 20	18 5/8 473	20 5/8 524	18 3/8 467	2 1/4 57	8 9/16 217	40 18	42 19	48 22
	1 25	18 5/8 473	20 5/8 524	18 3/8 467	2 1/4 57	8 9/16 217			
SF-V-BY-150 SF-V-BY-300 SF-V-BY-400 SF-V-BY-600	1/2 15	17 3/8 441	19 3/8 492	17 3/8 441	2 50	7 3/4 197			
	3/4 20	17 3/8 441	19 3/8 492	17 3/8 441	2 50	7 3/4 197	40 18	42 19	48 22
	1 25	18 5/8 473	20 5/8 524	18 5/8 473	2 1/4 57	8 9/16 217			

## SSF-V-BY

### ENGINEERING DATA

TYPE	PRESSURE RANGE psig/barg <sup>(1)</sup>	ORIFICE in/mm	MAX CAPACITY lb/h kg/h
SSF-V-F-125	0-125 0-8.5	1 25	5,750 2,608
SSF-V-F-200	0-200 0-14	7/8 22	6,400 2,903
SSF-V-F-400	0-400 0-28	9/16 14	5,300 2,409
SSF-V-F-600	0-600 0-42	1/2 12.7	5,200 2,360

Material and maximum temperature:

WCB, max. temp. 850°F (454°C), which is permissible, but not recommended for prolonged use above 800°F (426°C).

(1) Product will operate throughout entire pressure range, however selection closest to the Maximum operating pressure is recommended for maximum efficiency.

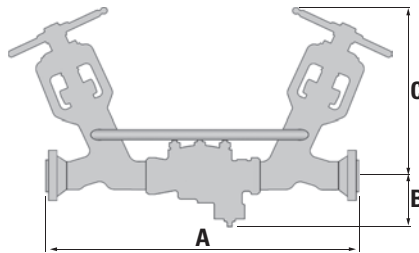

### DIMENSIONS AND WEIGHTS

TYPE	SIZE NPS/DN	A FACE TO FACE			B CENTER TO BOTTOM	C CENTER TO TOP	WEIGHT lb/kg		
		SCR/ SW	BW	FLG			SCR/ SW	BW	FLG
SSF-V-BY-125	2 50	31 787	33 838	31 787	5 3/8 137	16 11/16 424	198 90	198 90	200 91
	1 1/2 40	29 737							
SSF-V-BY-200 SSF-V-BY-400 SSF-V-BY-600	2 50	29 737	31 787	29 737	5 3/8 137	15 9/16 395	119 54	123 56	146 66

# VELAN PIPING KING PACKAGE UNITS

**N-V-BY-150, N-V-BY-300,  
N-V-BY-675, N-V-BY-900,  
N-V-BY-1500, N-V-BY-2500,  
N-V-BY-2600**

## ENGINEERING DATA

TYPE	PRESSURE RANGE psig/barg	ORIFICE in/mm	MAX. CAPACITY lb/h kg/h
<b>N-V-BY-150</b> (1)(2)(4)	0-150	1/2	2,800
	0-10.5		1,272
<b>N-V-BY-300</b> (1)(2)(4)	0-300	12.7	3,500
	0-21		1,590
<b>N-V-BY-675</b> (1)(2)(4)	0-675	5/16	2,900
	0-46.5		1,315
<b>N-V-BY-900</b> (1)(2)(4)	0-900	1/4	1,850
	0-62		8,41
<b>N-V-BY-1500</b> (1)(2)(4)	0-1500	6.4	2,100
	0-103		955
<b>N-V-BY-2500</b> (2)	500-2500	5/16	955
	34.5-172		2,182
<b>N-V-BY-2600</b> (3)	500-2600	8	4,900
	34.5-179		2,227

Material and maximum temperature:

(1) A105/WCB, max. temp. 850°F (454°C) which is permissible, but not recommended for prolonged use above 800°F (426°C),

(2) F22, max. temp. 1,050°F (565°C),

(3) F91, max. temp. 1,100°F (593°C).

(4) Product will operate throughout entire pressure range, however selection closest to the Maximum operating pressure is recommended for maximum efficiency.

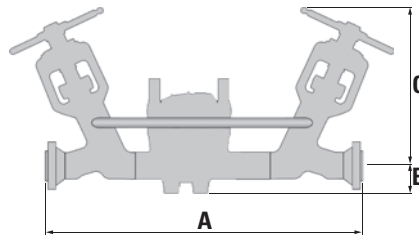

Also available with Velan Power ball valve:

- Two isolating
- Three bypass valves

## DIMENSIONS AND WEIGHTS

TYPE	SIZE NPS/DN	A FACE TO FACE			B CENTER TO BOTTOM	C CENTER TO TOP	WEIGHT lb/kg		
		SCR/SW	BW	FLG			SCR/SW	BW	FLG
<b>N-V-BY-150</b>	1/2	18 1/2	20 1/2	18 1/2	2	7 3/4	36	39	42
	15	470	521	470	50	197	16	18	19
<b>N-V-BY-300</b>	3/4	19 3/4	21 3/4	20 1/4	2 1/4	8 9/16	57	60	63
	20	502	552	514	57	217	26	27	29
<b>N-V-BY-675</b>	1	22 5/8	24 5/8	23 1/8	2 11/16	11 1/2	69	72	75
	25	575	625	587	68	292	31	33	34
<b>N-V-BY-900</b>	1/2	22 1/2	24 1/2	24	2 7/8	9 1/8	96	100	110
	15	572	622	610	73	232	43	45	50
<b>N-V-BY-1500</b>	3/4	25 3/8	27 3/8	26 7/8	3	12 1/4	120	125	140
	20	645	695	683	76	311	54	57	63
<b>N-V-BY-2500</b>	1	28	30	29 1/2	4 1/4	16 1/2	170	175	190
	25	711	762	749	108	419	77	79	86

**SPF0-V-BY TO SPF7-V-BY  
SP6-V-BY TO SP8-V-BY**

## ENGINEERING DATA

TYPE	PRESSURE RANGE psig/barg <sup>(3)</sup>	ORIFICE in/mm	MAX. CAPACITY lb/h kg/h
<b>SPF0-V-BY</b> (1)(2)	10-200	7/8	17,000
	0.69-14		7,727
<b>SPF1-V-BY</b> (1)(2)	10-350	22	19,000
	0.69-24		8,636
<b>SPF2-V-BY</b> (1)(2)	10-600	22	22,000
	0.69-42		10,000
<b>SPF3-V-BY</b> (1)(2)	10-1500	22	27,000
	0.69-103		12,273
<b>SPF4-V-BY</b> (1)	10-200	1 3/8	38,000
	0.69-14		17,272
<b>SPF5-V-BY</b> (1)	10-350	35	43,000
	0.69-24		19,545
<b>SPF6-V-BY</b> (1)	10-600	35	49,000
	0.69-42		22,272
<b>SPF7-V-BY</b> (1)(3)	10-1500	35	63,000
	0.69-103		28,636
<b>SP6-V-BY</b> (1)	10-200	2	90,000
	0.69-14		40,909
<b>SP7-V-BY</b> (1)	10-600	51	130,000
	0.69-42		59,090
<b>SP8-V-BY</b> (1)	10-1500	51	160,000
	0.69-103		72,727

Material and maximum temperature:

(1) A105/WCB, max. temp. 850°F (454°C) which is permissible, but not recommended for prolonged use above 800°F (426°C),

(2) F22, max. temp. 1,050°F (565°C),

(3) Product will operate throughout entire pressure range, however selection closest to the Maximum operating pressure is recommended for maximum efficiency.

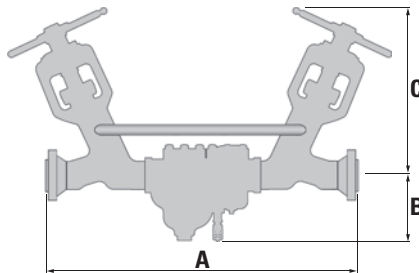

## DIMENSIONS AND WEIGHTS

TYPE	SIZE NPS/DN	A FACE TO FACE			B CENTER TO BOTTOM	C CENTER TO TOP	WEIGHT lb/kg		
		SCR/SW	BW	FLG			SCR/SW	BW	FLG
<b>SPF0-V-BY</b>	1	23 1/8	25 1/8	23 1/8 <sup>(1)</sup>	2 11/16	11 1/2	90	93	118
	25	587	638	587	68	292			
<b>SPF1-V-BY</b>	1 1/2	25 3/4	27 3/4	25 3/4 <sup>(1)</sup>	5 3/8	15 9/16	41	42	63
	40	654	705	654	137	395			
<b>SPF2-V-BY</b>	40	654	705	654	137	395	167	170	217
<b>SPF4-V-BY</b>	1 1/2	26 3/4	28 3/4	26 3/4 <sup>(2)</sup>	5 3/8	15 9/16	75	77	98
	40	679	730	679	137	395			
<b>SPF5-V-BY</b>	2	28 3/4	30 3/4	28 3/4 <sup>(2)</sup>	5 3/8	16 11/16	275	275	286
<b>SPF7-V-BY<sup>(2)</sup></b>	50	730	781	730	137	424	125	125	130
	<b>SP8-V-BY<sup>(3)</sup></b>								
<b>SP6-V-BY</b>		2	36	38	36 <sup>(3)</sup>	5 3/8	16 11/16	275	275
	50	914	965	914					
	2 1/2	38	38	38 <sup>(3)</sup>					
	65	965	965	965					
<b>SP7-V-BY</b>	3	38	38	38 <sup>(3)</sup>	137	424	125	125	130
<b>SP8-V-BY<sup>(3)</sup></b>	80	965	965	965					

(1) For SPF3-V-BY with flanged connection, A (face to face) for 1" is 23 5/8" (600 mm) and for 1 1/2" is 26 1/4" (669 mm).

(2) For SPF7-V-BY with flanged connection, A (face to face) for 1 1/2" is 27 1/4" (692 mm) and for 2" is 31 3/4" (806 mm).

(3) For SP8-V-BY with flanged connection, A (face to face) is 39" (991 mm) for all sizes.

# VELAN MONOVALVE FLOAT BIMETALLIC STEAM TRAPS

**Type MFT/MFTS for positive drainage of unit heaters and process equipment**

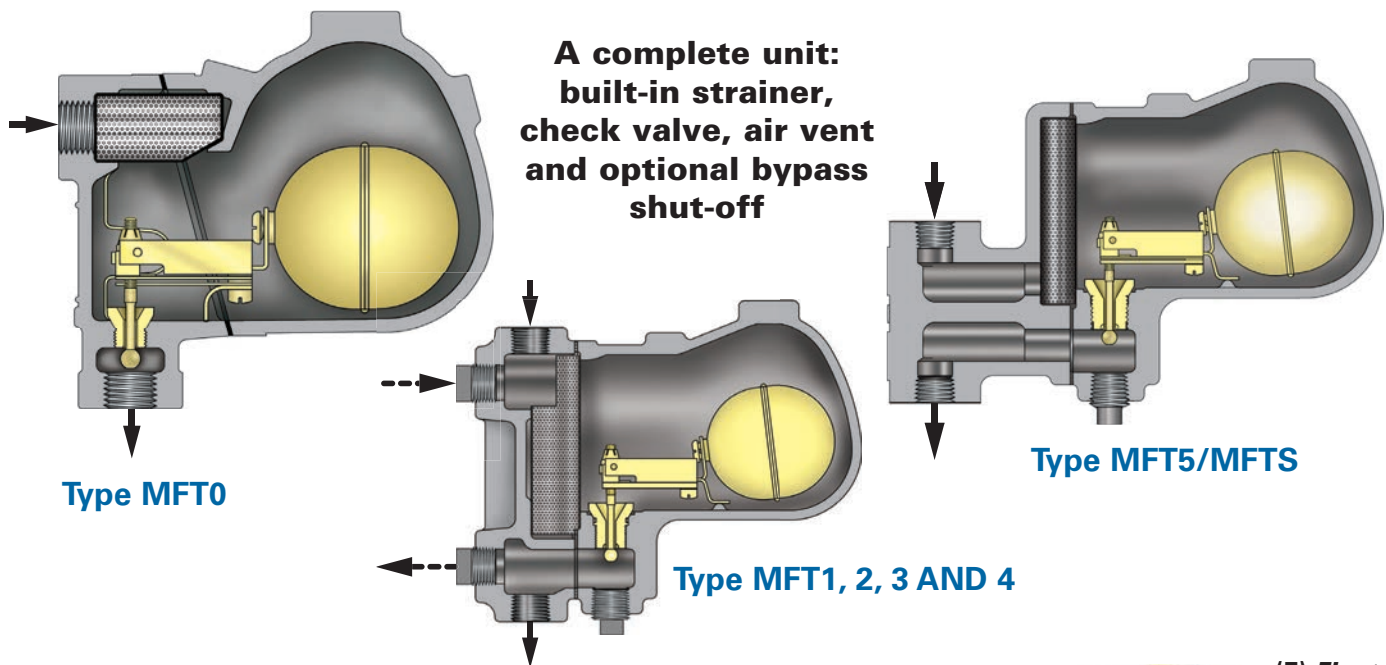

## DESIGN FEATURES

- Positive closing and condensate drainage**  
 The bimetallic element is a function of the saturated steam curve (pages 4 and 5) and its sensitivity to the temperature change assures an immediate reaction to both steam and condensate for the entire pressure range. At saturated steam temperature the valve is closed as on a standard bimetallic steam trap, however, in this type any condensate build-up even at saturated steam temperature is discharged at the same rate. As it reaches the trap, the float becomes buoyant and opens the valve mechanically (see page 7).
- Stainless steel float and trim**
- Simple installation**  
 Multiple inlet and outlet connections facilitate installation.
- Integral strainer**  
 Stainless steel screens are integral to protect the trap operating mechanism from damage by dirt or scale. No extra fittings or installation costs are required. Free strainer area minimum 5 to 1. Perforation is 0.031" (0.8 mm).
- Integral check valve operation**  
 The main valve acts as a check valve preventing back flow.
- Stainless steel pivots**  
 Assure adequate protection against wear.
- Seat (J) CoCr alloy hardfaced**  
 Increases resistance to the high degree of wear through velocity of flow, dirt, and scale.

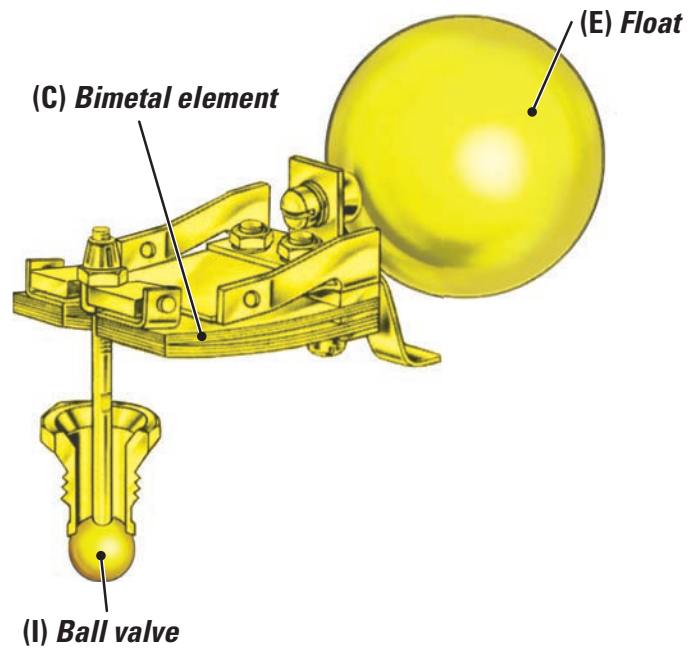

- Guaranteed against water hammer.**  
 The down-stream valve acts as a release valve on the excess water pressure without damage to internal parts.
- Freeze proof installation**  
 without insulation – complete drainage when cold.
- Other options**  
 NPT blow down plug, strainer blowdown valve, and Piping King Units.

# VELAN MONOVALVE FLOAT BIMETALLIC STEAM TRAPS

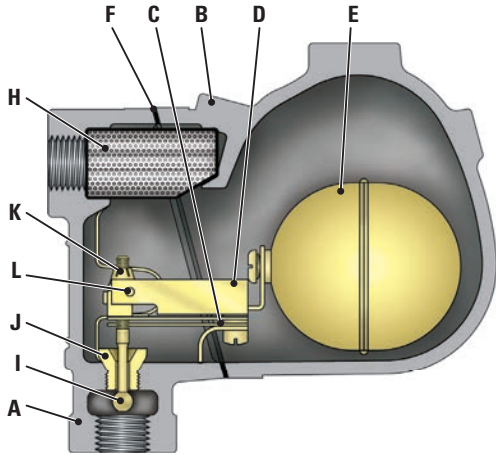

## STANDARD MATERIALS

PART	MATERIALS
A	Body Cast iron Gr.250
B	Cover Same as body material
C	Bimetal element Truflex GB-14
D	Bimetal holder Stainless steel
E	Float Stainless steel
F	Cover gasket Stainless steel with non-asbestos filler
G	Cover screw High tensile steel Gr. S
H	Strainer Stainless steel
I	Stem and ball Stainless steel, ball 58Rc
J	Seat SS 416 hardened
K	Self lock adjusting nut Stainless steel
L	Pivot plug Stainless steel

NOTE: Part 'G' is not shown for clarity

## APPLICATIONS

Boiler headers, steam mains, branch lines, unit heaters, shell and tube heat exchangers, jacketed kettles, rotating dryers, flash tanks, laundry ironers and steam separators.

## CONNECTIONS

- Screwed

## Type MFT0

### ENGINEERING DATA

PRESSURE RANGE (1) psig/barg	PMO psig/barg	MATERIAL	MAX TEMP °F/°C	ORIFICE in/mm	MAX CAPACITY lb/hr/kg/hr
0-125 0-8.5	125 8.5	Cast iron Gr.250	428 220	7/32 5.5	1,650 750

(1) Product will operate throughout entire pressure range, however selection closest to the Maximum operating pressure is recommended for maximum efficiency.

PMA = Maximum allowable pressure: 260psig@100°F (18bar@38°C)

TMA = Maximum allowable temperature: 428°F (220°C)

Maximum cold hydrostatic test pressure: 400psig (27.5bar)

TMO = Maximum operating temperature = TMA

PMO = Maximum operating pressure: (see Engineering data table)

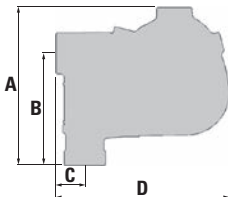

## DIMENSIONS AND WEIGHTS

SIZE NPS/DN	A HEIGHT	B(1) CENTER TO FACE	C(2) CENTER TO TOP	D LENGTH	WEIGHT lb/kg
1/2 15	3/4 20	6 1/8 156	4 3/8 111	1 1/8 29	8.75 4

(1) Center of inlet to outlet face (2) Center of outlet to inlet face

## CONDENSATE CAPACITY

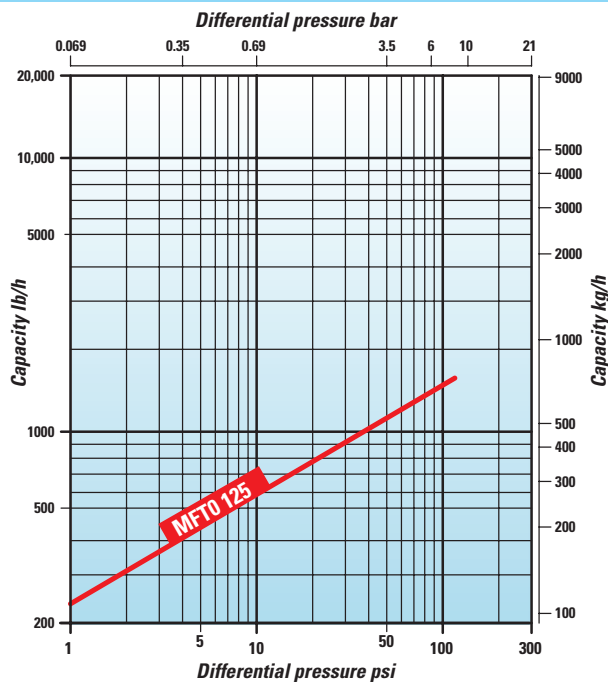

Maximum cold water capacity x 3.5

The performance graph indicates the continuous discharge capacities of condensate per hour at various pressure differentials across the trap.

## PRESSURE / TEMPERATURE LIMITS

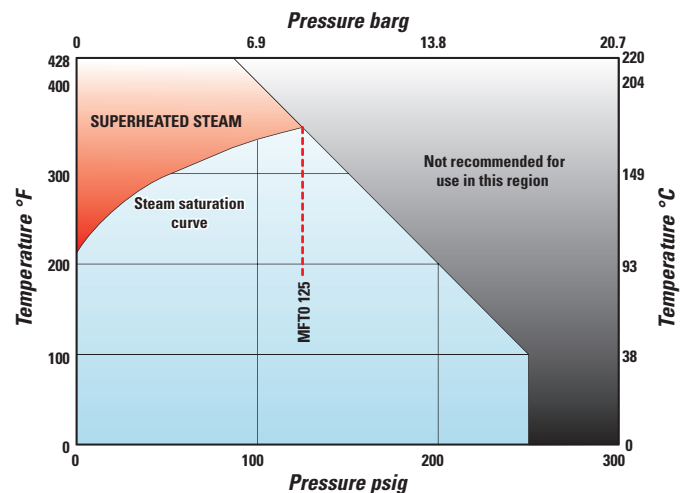

----- Pressure limit for trap type

# VELAN MONOVALVE FLOAT BIMETALLIC STEAM TRAPS

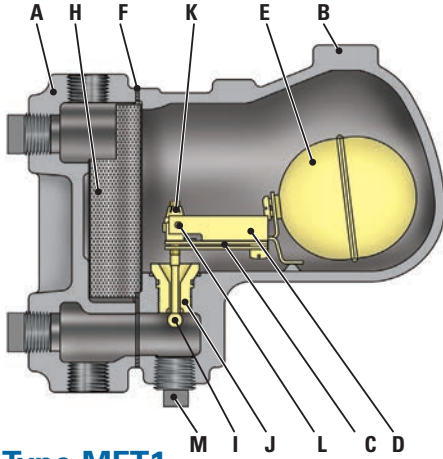

Type MFT1

## STANDARD MATERIALS

PART		MATERIALS
A	Body	Cast iron Gr.250
B	Cover	Same as body material
C	Bimetal element	Truflex GB-14
D	Bimetal holder	Stainless steel
E	Float	Stainless steel
F	Cover gasket	Stainless steel with non-asbestos filler
G	Cover screw	High tensile steel Gr. S
H	Strainer	Stainless steel
I	Stem and ball	Stainless steel, ball 58Rc
J	Seat	SS hardfaced with CoCr alloy
K	Self lock adjusting nut	Stainless steel
L	Pivot plug	Stainless steel
M	Test plug 1/2" NPT	Steel
N	Strainer plug 1/8" NPT	Steel

NOTE: Part 'G' and 'N' are not shown for clarity

## APPLICATIONS

Boiler headers, steam mains, branch lines, unit heaters, shell and tube heat exchangers, jacketed kettles, rotating dryers, flash tanks, laundry ironers and steam separators.

## CONNECTIONS

- Screwed

## ENGINEERING DATA

PRESSURE RANGE (1) psig/barg	PMO psig/barg	MATERIAL	MAX TEMP °F/°C	ORIFICE in/mm	MAX CAPACITY lb/hr/kg/hr
0-15 0-1	15 1	Cast iron Gr.250	428 220	3/8 9.5	3,250 1,477
0-50 0-3.5	50 3.5			7/32 5.5	1,250 568
0-125 0-8.5	125 8.5				1,700 772

PMA = Maximum allowable pressure: 260psig@100°F (18bar@38°C)

TMA = Maximum allowable temperature: 428°F (220°C)

Maximum cold hydrostatic test pressure: 400psig (27.5bar)

TMO = Maximum operating temperature = TMA

PMO = Maximum operating pressure: (see Engineering data table)

(1) Product will operate throughout entire pressure range, however selection closest to the Maximum operating pressure is recommended for maximum efficiency.

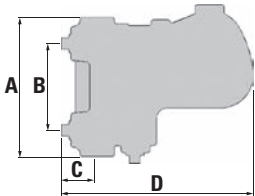

## DIMENSIONS AND WEIGHTS

SIZE NPS/DN			A(1) FACE TO FACE	B(2) CENTER TO CENTER	C(3) CENTER TO FACE	D LENGTH	WEIGHT lb/kg
1/2 15	3/4 20	1 25	6 5/8 168	3 15/16 100	1 3/8 35	8 5/16 211	12 5.5

(1) Vertical connection. (2) Horizontal connection. (3) Center of vertical outlet to face of horizontal outlet.

## CONDENSATE CAPACITY

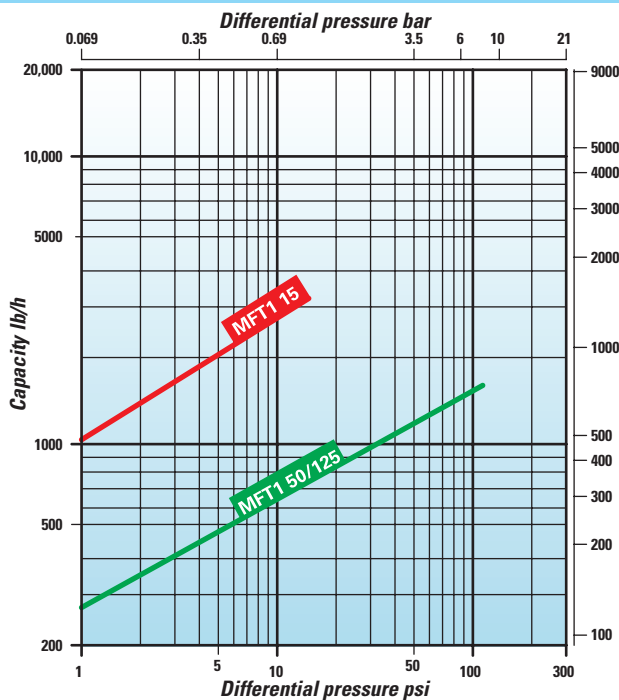

Maximum cold water capacity x 3.5

The performance graph indicates the continuous discharge capacities of condensate per hour at various pressure differentials across the trap.

## PRESSURE / TEMPERATURE LIMITS

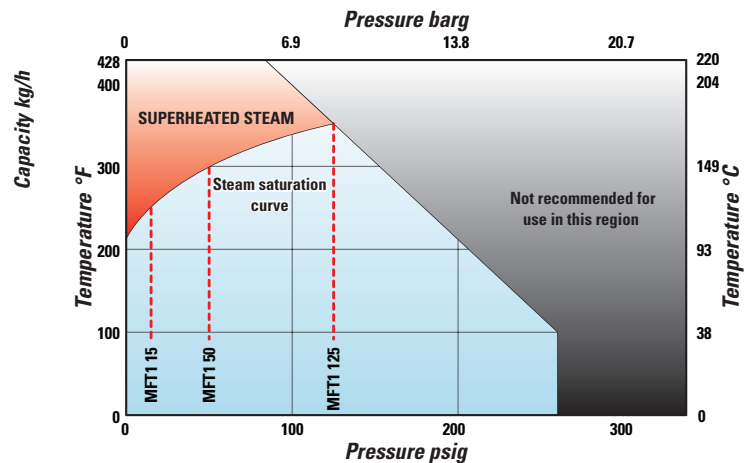

----- Pressure limit for trap type



# VELAN MONOVALVE FLOAT BIMETALLIC STEAM TRAPS

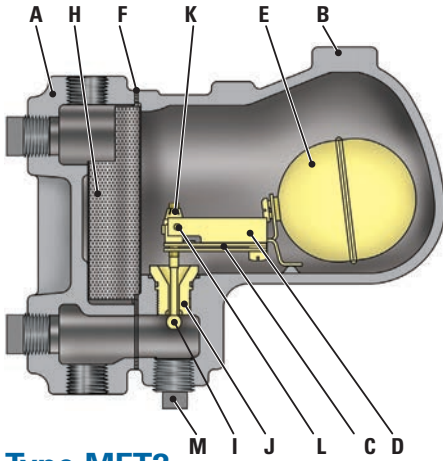

## Type MFT2

### STANDARD MATERIALS

PART	MATERIALS
A	Body
B	Cover
C	Bimetal element
D	Bimetal holder
E	Float
F	Cover gasket
G	Cover screw
H	Strainer
I	Stem and ball
J	Seat
K	Self lock adjusting nut
L	Pivot plug
M	Test plug 1/2" NPT
N	Strainer plug 3/8" NPT

NOTE: Part 'G' and 'N' are not shown for clarity.

### APPLICATIONS

Boiler headers, steam mains, branch lines, unit heaters, air handlers, process air heaters, steam absorption machine (chiller), shell and tube heat exchangers, jacketed kettles, rotating dryers, flash tanks and steam separators.

### CONNECTIONS

- Screwed

### ENGINEERING DATA

PRESSURE RANGE <sup>(1)</sup> psig/barg	PMO psig/barg	MATERIAL	MAX TEMP °F/°C	ORIFICE in/mm	MAX CAPACITY lb/hr/kg/hr
0-15 0-1	15 1	Cast iron Gr.250	428 220	1/2 12.7	7,000 3,182
0-50 0-3.5	50 3.5			5/16 8	3,200 1,455
0-125 0-8.5	125 8.5			1/4 6.4	2,600 1,182
0-200 0-14	200 14			7/32 5.5	2,000 909

PMA = Maximum allowable pressure: 260psig@100°F (18bar@38°C)

TMA = Maximum allowable temperature: 428°F (220°C)

Maximum cold hydrostatic test pressure: 400psig (27.5bar)

TMO = Maximum operating temperature = TMA

PMO = Maximum operating pressure: (see Engineering data table)

(1) Product will operate throughout entire pressure range, however selection closest to the Maximum operating pressure is recommended for maximum efficiency.

### DIMENSIONS AND WEIGHTS

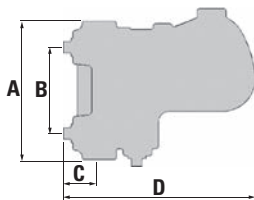

SIZE NPS/DN	A <sup>(1)</sup> FACE TO FACE	B <sup>(2)</sup> CENTER TO CENTER	C <sup>(3)</sup> CENTER TO FACE	D LENGTH	WEIGHT lb/kg
3/4 1	7 11/16	4 3/4	1 7/16	9 3/8	15
20 25	195	121	37	238	7
1 1/4 1 1/2	8 203	4 1/2 114	1 3/4 44	10 3/8 264	17 8

(1) Vertical connection. (2) Horizontal connection. (3) Center of vertical outlet to face of horizontal outlet.

### CONDENSATE CAPACITY

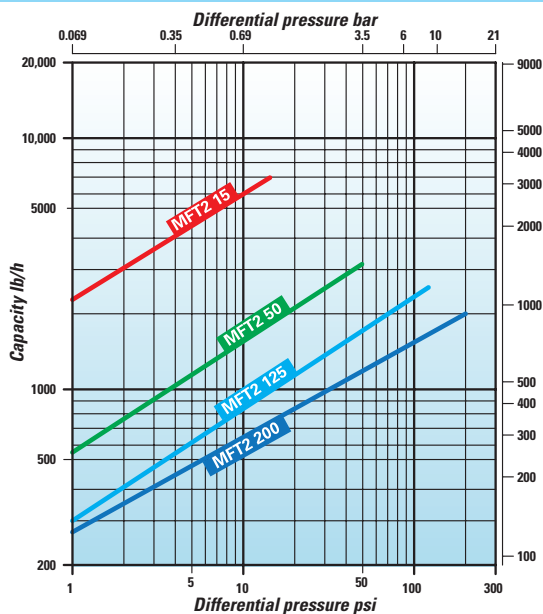

Maximum cold water capacity x 3.5

The performance graph indicates the continuous discharge capacities of condensate per hour at various pressure differentials across the trap.

### PRESSURE / TEMPERATURE LIMITS

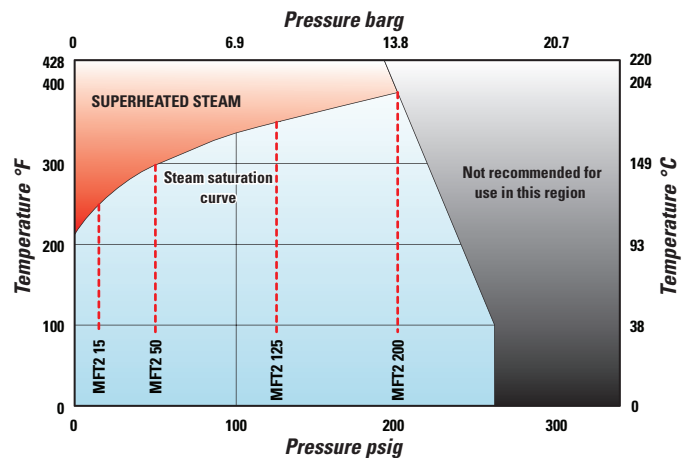

----- Pressure limit for trap type

# VELAN MONOVALVE FLOAT BIMETALLIC STEAM TRAPS

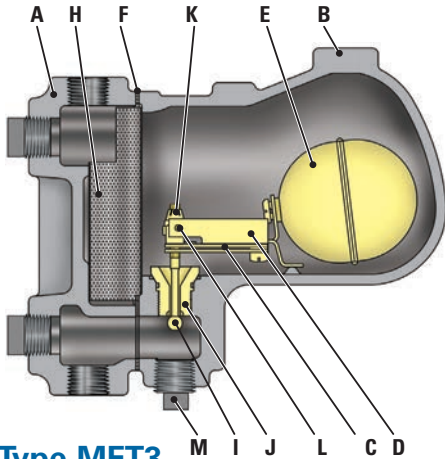

## STANDARD MATERIALS

PART	MATERIALS
A	Body Cast iron Gr.250
B	Cover Same as body material
C	Bimetal element Truflex GB-14
D	Bimetal holder Stainless steel
E	Float Stainless steel
F	Cover gasket Stainless steel with non-asbestos filler
G	Cover screw High tensile steel Gr. S
H	Strainer Stainless steel
I	Stem and ball Stainless steel, ball 58Rc
J	Seat SS hardfaced with CoCr alloy
K	Self lock adjusting nut Stainless steel
L	Pivot plug Stainless steel
M	Test plug 1" NPT Steel
N	Strainer plug 3/4" NPT Steel

## APPLICATIONS

Boiler headers, steam mains, branch lines, unit heaters, air handlers, process air heaters, steam absorption machine (chiller), shell and tube heat exchangers, jacketed kettles, rotating dryers, flash tanks and steam separators.

## CONNECTIONS

- Screwed

## Type MFT3

## ENGINEERING DATA

PRESSURE RANGE (1) psig/barg	PMO psig/barg	MATERIAL	MAX TEMP °F/°C	ORIFICE in/mm	MAX CAPACITY lb/hr/kg/hr
0-15 0-1	15 1	Cast iron Gr.250	428 220	5/8 16	12,000 5,455
0-50 0-3.5	50 3.5			7/16 11	8,000 3,636
0-125 0-8.5	125 8.5			5/16 8	4,500 2,045
0-200 0-14	200 14			1/4 6.4	3,200 1,455

PMA = Maximum allowable pressure: 260psig@100°F (18bar@38°C)

TMA = Maximum allowable temperature: 428°F (220°C)

Maximum cold hydrostatic test pressure: 400psig (27.5bar)

TMO = Maximum operating temperature = TMA

PMO = Maximum operating pressure: (see Engineering data table)

(1) Product will operate throughout entire pressure range, however selection closest to the Maximum operating pressure is recommended for maximum efficiency.

## DIMENSIONS AND WEIGHTS

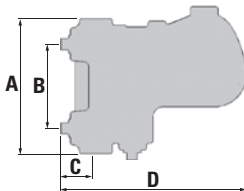

SIZE NPS/DN	A (1) FACE TO FACE	B(2) CENTER TO CENTER	C(3) CENTER TO FACE	D LENGTH	WEIGHT lb/kg
1 1/2 40	9 229	5 1/2 140	1 3/4 44	12 3/4 324	33 15
2 50	10 1/4 260	5 5/8 143	2 1/4 57	13 1/2 343	35 16

(1) Vertical connection (2) Horizontal connection (3) Center of vertical outlet to face of horizontal outlet

## CONDENSATE CAPACITY

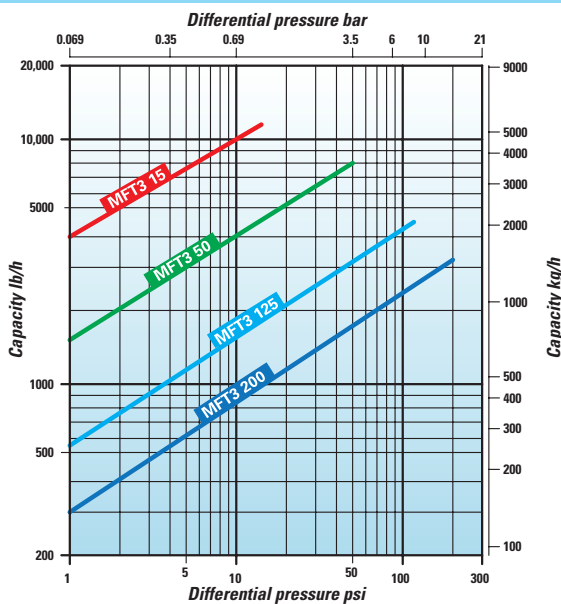

Maximum cold water capacity x 3.5

The performance graph indicates the continuous discharge capacities of condensate per hour at various pressure differentials across the trap.

## PRESSURE / TEMPERATURE LIMITS

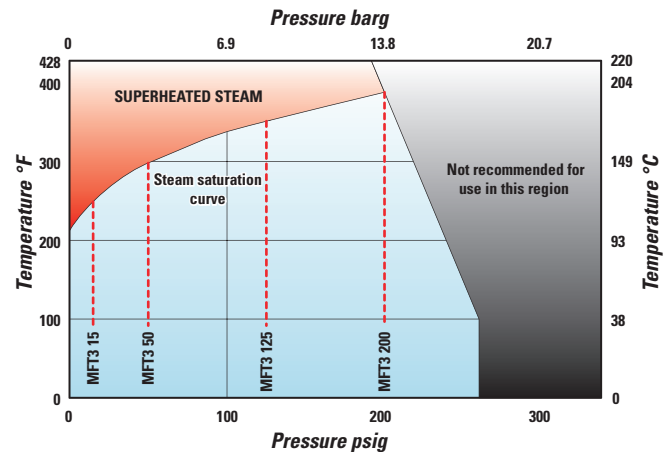

----- Pressure limit for trap type

# VELAN MONOVALVE FLOAT BIMETALLIC STEAM TRAPS

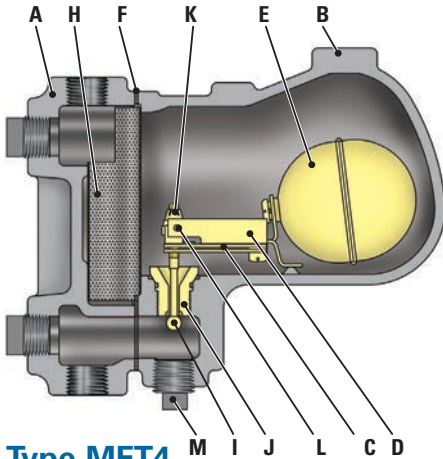

Type MFT4

## STANDARD MATERIALS

PART		MATERIALS
A	Body	Cast iron Gr.250
B	Cover	Same as body material
C	Bimetal element	Truflex GB-14
D	Bimetal holder	Stainless steel
E	Float	Stainless steel
F	Cover gasket	Stainless steel with non-asbestos filler
G	Cover screw	High tensile steel Gr. S
H	Strainer	Stainless steel
I	Stem and ball	Stainless steel, ball 58Rc
J	Seat	SS hardfaced with CoCr alloy
K	Self lock adjusting nut	Stainless steel
L	Pivot plug	Stainless steel
M	Test plug 1" NPT	Steel
N	Strainer plug 3/4" NPT	Steel

NOTE: Part 'G' & 'N' are not shown for clarity.

## APPLICATIONS

Boiler headers, steam mains, branch lines, unit heaters, air handlers, process air heaters, steam absorption machine (chiller), shell and tube heat exchangers, jacketed kettles, rotating dryers, flash tanks and steam separators.

## CONNECTIONS

- Screwed

## ENGINEERING DATA

PRESSURE RANGE (1) psig/barg	PMO psig/barg	MATERIAL	MAX TEMP °F/°C	ORIFICE in/mm	MAX CAPACITY lb/hr/kg/hr
0-15 0-1	15 1	Cast iron Gr.250	428 220	3/4 19	17,500 7,955
0-50 0-3.5	50 3.5			1/2 12.7	12,000 5,455
0-125 0-8.5	125 8.5			3/8 9.5	8,000 3,636
0-200 0-14	200 14			5/16 8	5,800 2,636

PMA = Maximum allowable pressure: 260psig@100°F (18bar@38°C)

TMA = Maximum allowable temperature: 428°F (220°C)

Maximum cold hydrostatic test pressure: 400psig (27.5bar)

TMO = Maximum operating temperature = TMA

PMO = Maximum operating pressure: (see Engineering data table)

(1) Product will operate throughout entire pressure range, however selection closest to the Maximum operating pressure is recommended for maximum efficiency.

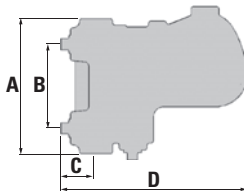

## DIMENSIONS AND WEIGHTS

SIZE NPS/DN	A (1) FACE TO FACE	B(2) CENTER TO CENTER	C(3) CENTER TO FACE	D LENGTH	WEIGHT lb/kg
2	11	6 1/2	2 1/4	14 1/2	51
50	279	165	57	368	23

(1) Vertical connection (2) Horizontal connection (3) Center of vertical outlet to face of horizontal outlet

## CONDENSATE CAPACITY

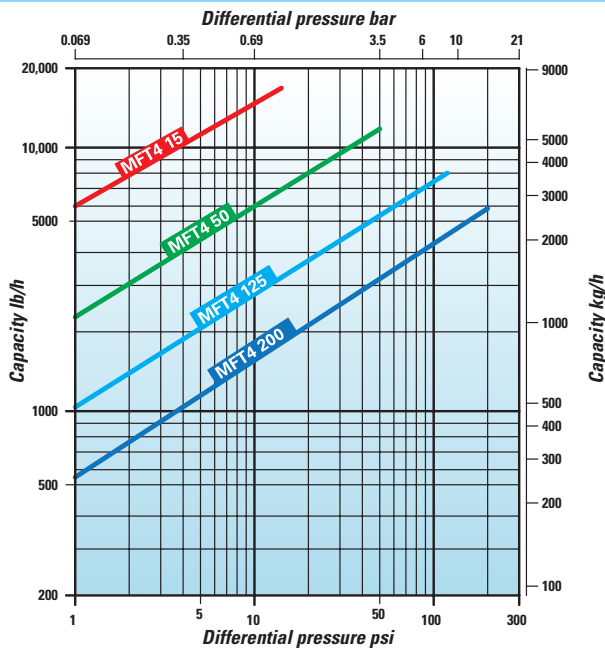

Maximum cold water capacity x 3.5

The performance graph indicates the continuous discharge capacities of condensate per hour at various pressure differentials across the trap.

## PRESSURE / TEMPERATURE LIMITS

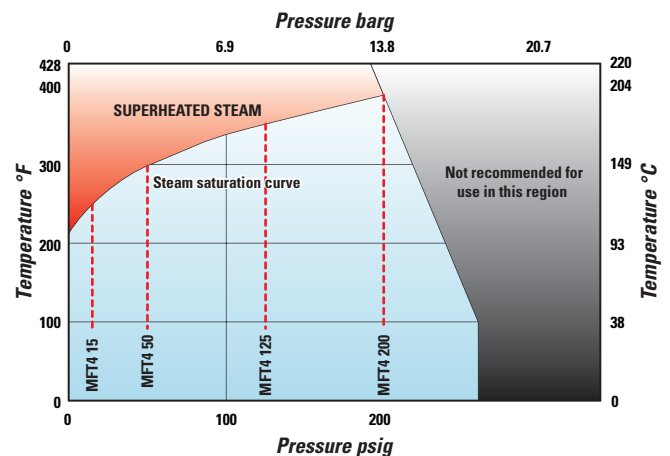

----- Pressure limit for trap type

# VELAN MONOVALVE FLOAT BIMETALLIC STEAM TRAPS

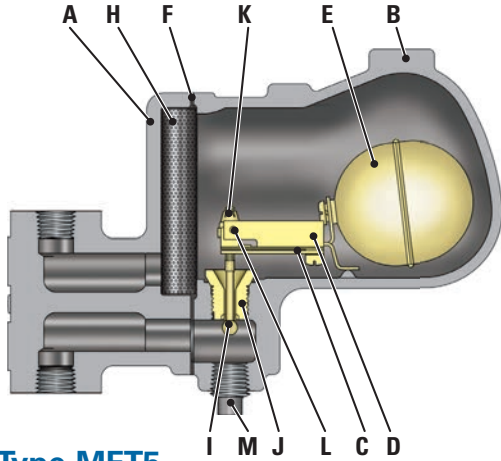

Type MFT5

## STANDARD MATERIALS

PART		MATERIALS
A	Body	Cast iron Gr.250
B	Cover	Same as body material
C	Bimetal element	Truflex GB-14
D	Bimetal holder	Stainless steel
E	Float	Stainless steel
F	Cover gasket	Stainless steel with non-asbestos filler
G	Cover screw	High tensile steel Gr. S
H	Strainer	Stainless steel
I	Stem and ball	Stainless steel, ball 58Rc
J	Seat	SS hardfaced with CoCr alloy
K	Self lock adjusting nut	Stainless steel
L	Pivot plug	Stainless steel
M	Test plug 1/2" NPT	Steel
N	Strainer plug 1/2" NPT	Steel

NOTE: Part 'G' & 'N' are not shown for clarity

## APPLICATIONS

Boiler headers, steam mains, branch lines, unit heaters, shell and tube heat exchangers, jacketed kettles, rotating dryers, flash tanks and steam separators.

## CONNECTIONS

- Screwed

## ENGINEERING DATA

PRESSURE RANGE psig/barg (1)	PMO psig/barg	MATERIAL	MAX TEMP °F/°C	ORIFICE in/mm	MAX CAPACITY lb/hr/kg/hr
0-15 0-1	15 1	Cast iron Gr.250	428 220	3/8 9.5	3,300 1,477
0-50 0-3.5	50 3.5			7/32 5.5	1,250 568
0-125 0-8.5	125 8.5			7/32 5.5	1,700 772

PMA = Maximum allowable pressure: 260psig@100°F (18bar@38°C)  
 TMA = Maximum allowable temperature: 428°F (220°C)  
 Maximum cold hydrostatic test pressure: 400psig (27.5bar)  
 TMO = Maximum operating temperature = TMA  
 PMO = Maximum operating pressure: (see Engineering data table)

(1) Product will operate throughout entire pressure range, however selection closest to the Maximum operating pressure is recommended for maximum efficiency.

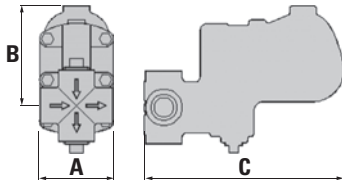

## DIMENSIONS AND WEIGHTS

SIZE NPS/DN			A FACE TO FACE SCR	B CENTER TO TOP	C LENGTH	WEIGHT lb/kg SCR
1/2 15	3/4 20	1 25	3 11/16 94	5 1/4 133	9 1/4 235	12 5.5

## CONDENSATE CAPACITY

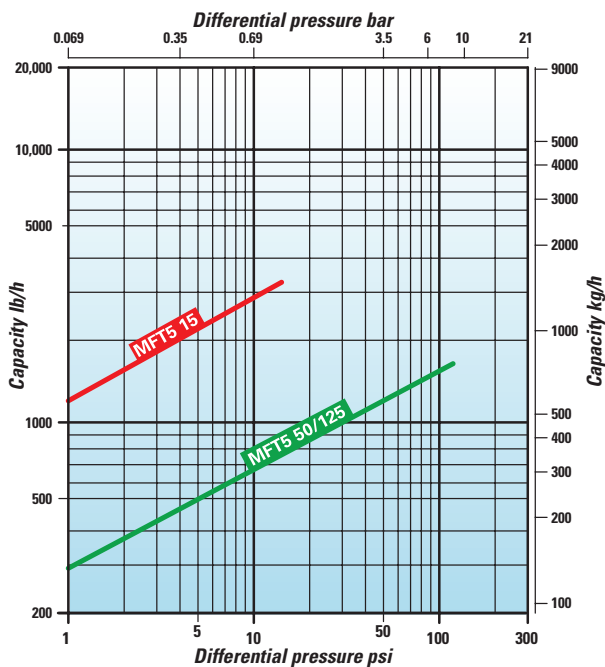

Maximum cold water capacity x 3.5

The performance graph indicates the continuous discharge capacities of condensate per hour at various pressure differentials across the trap.

## PRESSURE / TEMPERATURE LIMITS

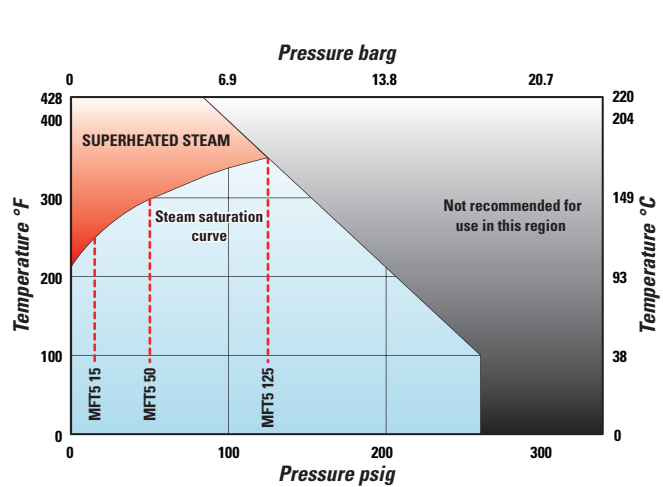

----- Pressure limit for trap type

# VELAN MONOVALVE FLOAT BIMETALLIC STEAM TRAPS

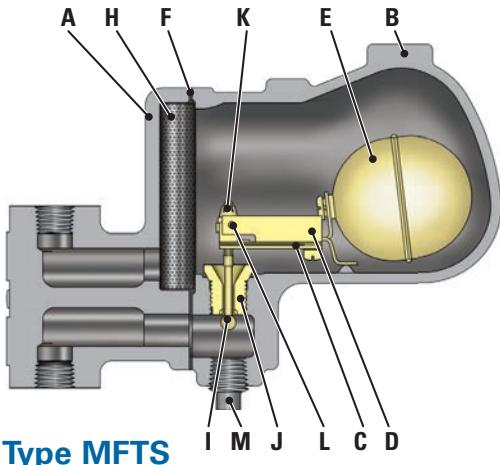

Type MFTS

## STANDARD MATERIALS

PART		MATERIALS
A	Body	Cast steel WCB
B	Cover	Same as body material
C	Bimetal element	Truflex GB-14
D	Bimetal holder	Stainless steel
E	Float	Stainless steel
F	Cover gasket	Stainless steel with non-asbestos filler
G	Cover screw	Chrome moly. alloy B7
H	Strainer	Stainless steel
I	Stem and ball	Stainless steel, ball 58Rc
J	Seat	SS hardfaced with CoCr alloy
K	Self lock adjusting nut	Stainless steel
L	Pivot plug	Stainless steel
M	Test plug 1/2" NPT	Steel
N	Strainer plug 1/8" NPT	Steel

## APPLICATIONS

Boiler headers, steam mains, branch lines, unit heaters, shell and tube heat exchangers, jacketed kettles, rotating dryers, flash tanks and steam separators.

## CONNECTIONS

- Screwed
- Socket-weld
- Butt-weld
- Flanged

## ENGINEERING DATA

PRESSURE RANGE psig/barg (1)	PMO psig/barg	MATERIAL	MAX TEMP °F/°C	ORIFICE in/mm	MAX CAPACITY lb/hr/kg/hr
0-150 0-10.5	150 10.5	Cast carbon steel WCB	650 343	5/16 8	4,200 1,909
0-230 0-16	230 16			7/32 5.5	1,900 863
0-300 0-21	300 21			7/32 5.5	2,100 955

(1) Product will operate throughout entire pressure range, however selection closest to the Maximum operating pressure is recommended for maximum efficiency.

PMA = Maximum allowable pressure: 320psig@100°F (22bar@38°C)  
 TMA = Maximum allowable temperature: 650°F (343°C)  
 Maximum cold hydrostatic test pressure: 600psig (41bar)  
 TMO = Maximum operating temperature = TMA  
 PMO = Maximum operating pressure: (see Engineering data table)

NOTE: Part 'G' & 'N' are not shown for clarity

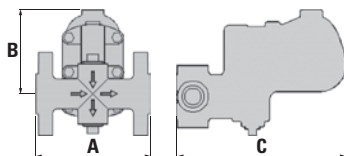

## DIMENSIONS AND WEIGHTS

SIZE NPS/DN	A FACE TO FACE			B CENTER TO TOP	C LENGTH	WEIGHT lb/kg				
	SCR/SW	BW	FLG			SCR/SW	BW	FLG		
1/2 15	3/4 20	1 25	3 11/16 94	9 11/16 246	6 152	5 1/4 133	9 1/4 235	18 8	20 9	30 14

## CONDENSATE CAPACITY

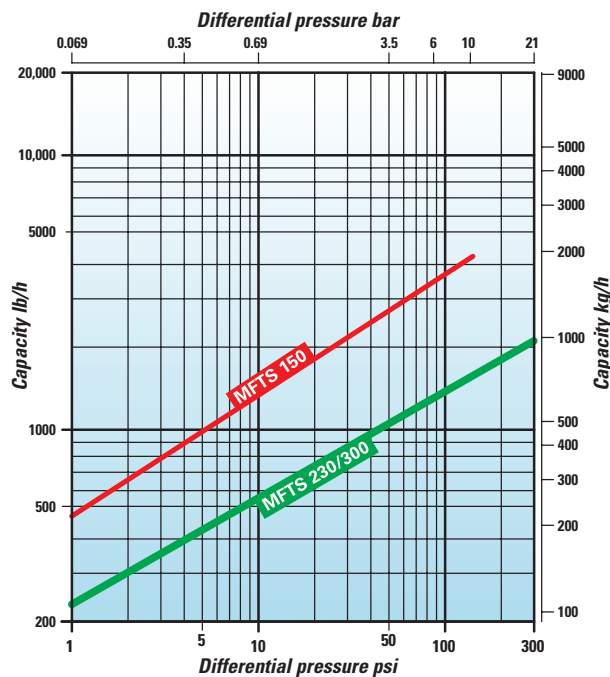

The performance graph indicates the continuous discharge capacities of condensate per hour at various pressure differentials across the trap.

## PRESSURE / TEMPERATURE LIMITS

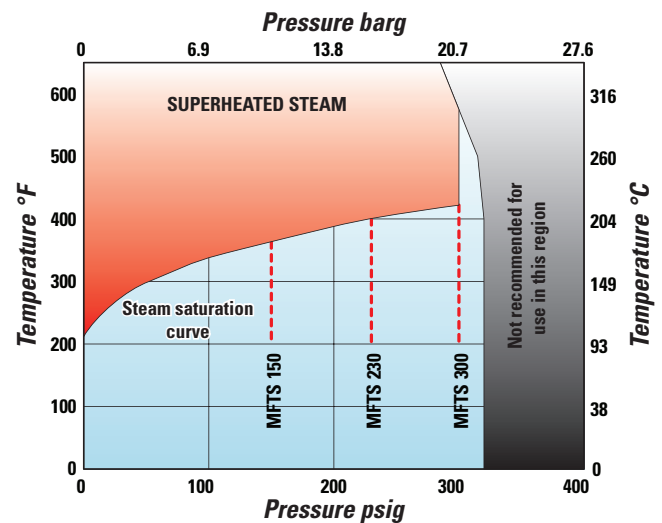

Maximum cold water capacity x 3.5

----- Pressure limit for trap type

# VELAN THERMODYNAMIC STEAM TRAPS

## FORGED RANGE



Type  
VTS

- **Seats CoCr alloy hardfaced**  
Velan forged trap seats are CoCr alloy hardfaced to increase their resistance to the high degree of wear through velocity of flow, dirt and scale.

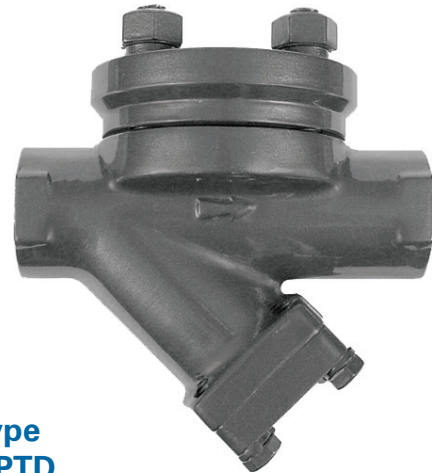

Type  
HPTD

## CAST RANGE



Type  
VTDS

- **Velan cast trap seats**  
Hardened by special induction hardening process with seat harder than disc to withstand continuous, prolonged operation.



Type  
VTD

## COMMON DESIGN FEATURES

- **Stainless steel hardened floating disc**  
Ground and lapped with seat replaceable in line.
- **Gaskets** are spiral wound, stainless steel with graphite. **Trim** is stainless steel
- **Integral strainer**  
Stainless steel screens are integral in all three models to protect the trap operating mechanism from damage by dirt or scale. No extra fittings or installation costs are required. Free strainer area minimum 5 to 1. Perforation is 0.031" (0.8 mm).
- **Positive closing**  
Every Velan trap closes tightly on saturated steam temperature. Positive closing for long periods on dry superheated steam lines has enormous advantages in power plant and marine service.
- **Freeze-proof installation**  
Velan traps do not require a reservoir of priming water in the body to operate when installed vertically with inlet on top, they drain completely when cold, and are therefore freeze-proof without insulation.
- **Positive condensate drainage** for process work.
- **All-position installation**  
Simplifies piping layout.

# VELAN THERMODYNAMIC STEAM TRAPS

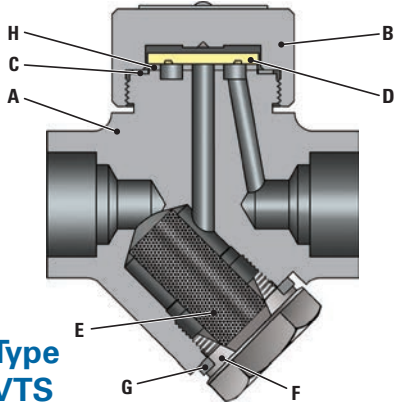

Type VTS

## STANDARD MATERIALS

PART	MATERIALS	
A	Body	Forged carbon steel A105 <sup>(1)</sup>
B	Cover	Same as body material
C	Cover gasket	Monel
D	Floating disc	Stainless steel, hardened
E	Strainer	Stainless steel
F	Strainer cover	Same as body material
G	Strainer cover gasket	Stainless steel
H	Seat	Hardfaced with CoCr alloy

(1) Consult works for F11 or F316 material

## APPLICATIONS

Boiler headers, steam mains, branch lines, tracer lines, sterilizers, multi-platen presses, laundry ironers, rubber and plastic moulding equipment.

## ENGINEERING DATA

PRESSURE RANGE psig/barg	PMO psig/barg	MAX TEMP °F/°C	MAX CAPACITY lb/hr/kg/hr
5-600 (0.34-41)	600 (41)	850 <sup>(1)</sup> 454	2,060 936

(1) Permissible, but not recommended for prolonged use above 800°F (426°C)

Max body design condition: ANSI/ASME 600  
 PMA = Maximum allowable pressure: 1480psig@100°F (102bar@38°C)  
 TMA = Maximum allowable temperature: 800°F (426°C)  
 Maximum cold hydrostatic test pressure: 2225psig (153.5bar)  
 TMO = Maximum operating temperature = TMA  
 PMO = Maximum operating pressure: (see Engineering data table)

## DIMENSIONS AND WEIGHTS

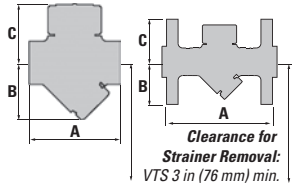

SIZE NPS/DN			A HEIGHT			B CENTER TO BOTTOM	C CENTER TO TOP	WEIGHT lb/kg		
			SCR/ SW	BW	FLG			SCR/ SW	BW	FLG
3/8	1/2	3/4	3 3/16	9 3/16	6 1/4	2 1/8	2 1/8	2	3	7
10	15	20	81	233	159	54	54	1	1.5	3

## CONDENSATE CAPACITY

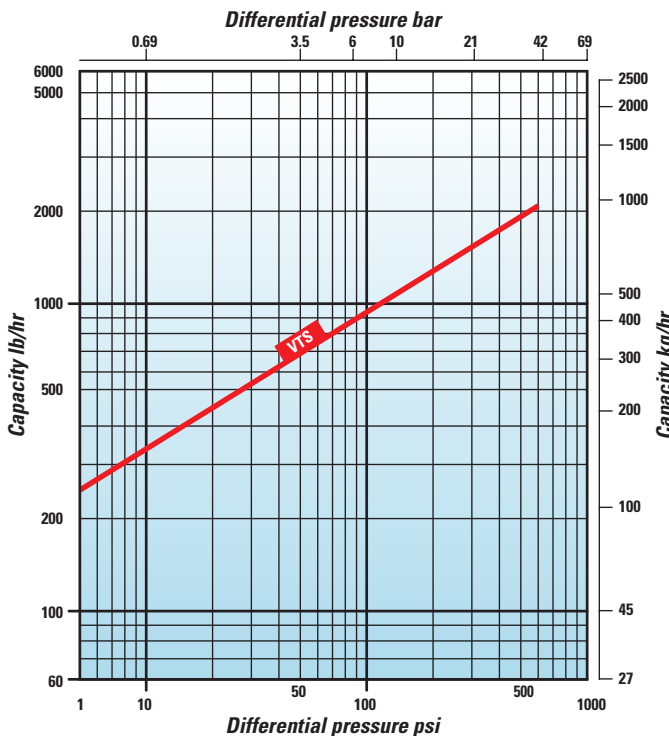

Maximum cold water capacity x 3.5

The performance graph indicates the continuous discharge capacities of condensate per hour at various pressure differentials across the trap.

## PRESSURE / TEMPERATURE LIMITS

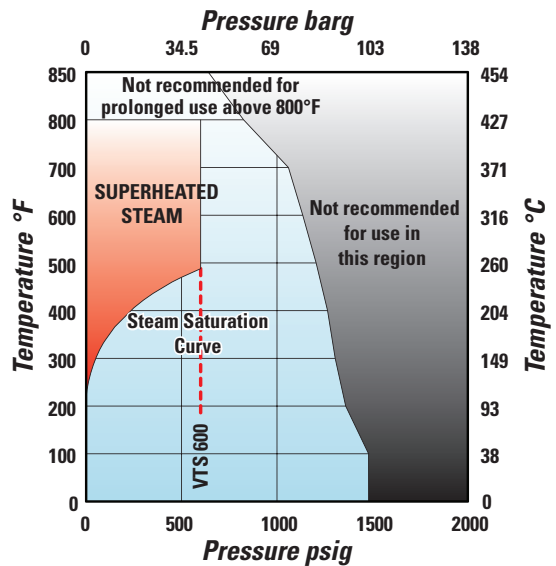

----- Pressure limit for trap type

# VELAN THERMODYNAMIC STEAM TRAPS

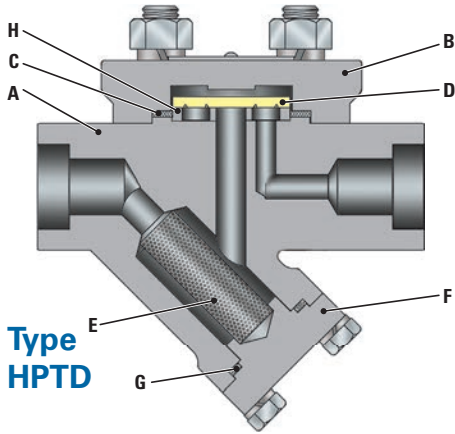

Type HPTD

## STANDARD MATERIALS

PART		MATERIALS
A	Body	Forged carbon steel A105 (C.Max. 0.25)
B	Cover	Same as body material
C	Cover gasket	SS with graphite filler
D	Floating disc	Stainless steel, hardened
E	Strainer	Stainless steel
F	Strainer cover	Same as body material
G	Strainer cover gasket	Stainless steel spiral wound with non-asbestos filler
H	Seat	Hardfaced with CoCr alloy

## APPLICATIONS

Boiler headers, steam mains, branch lines, soot blower drains and intermediate stage turbine drains.

## CONNECTIONS

- Screwed
- Socket-weld
- Butt-weld
- Flanged

## ENGINEERING DATA

PRESSURE RANGE psig/barg	PMO psig/barg	MATERIAL	MAX TEMP °F/°C	MAX CAPACITY lb/hr/kg/hr
5-1000 (0.34-69)	1000 (69)	A105	800 426	5,500 2,500

Max body design condition: ANSI/ASME 900  
 PMA = Maximum allowable pressure: 2220psig@100°F (153bar@38°C)  
 TMA = Maximum allowable temperature: 800°F (427°C)  
 Maximum cold hydrostatic test pressure: 3350psig (230bar)  
 TMO = Maximum operating temperature = TMA  
 PMO = Maximum operating pressure: (see Engineering data table)

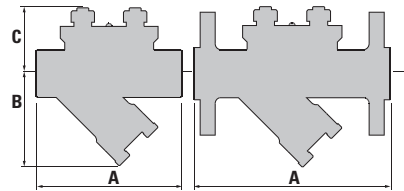

Clearance for Strainer Removal:  
HPTD 5 in (127 mm) min.

## DIMENSIONS AND WEIGHTS

SIZE NPS/DN			A FACE TO FACE			B CENTER TO BOTTOM	C CENTER TO TOP	WEIGHT lb/kg		
			SCR/SW	BW	FLG			SCR/SW	BW	FLG
1/2	3/4	1	6 1/8	12 1/8	10 1/8	4	2 7/8	18	20	26
15	20	25	155	308	257	102	73	8	9	12

## CONDENSATE CAPACITY

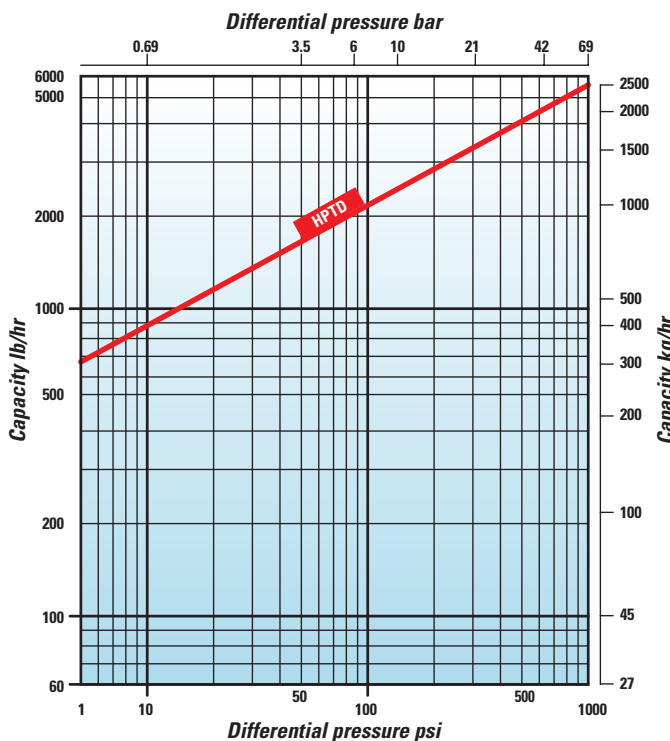

Maximum cold water capacity x 3.5

The performance graph indicates the continuous discharge capacities of condensate per hour at various pressure differentials across the trap.

## PRESSURE / TEMPERATURE LIMITS

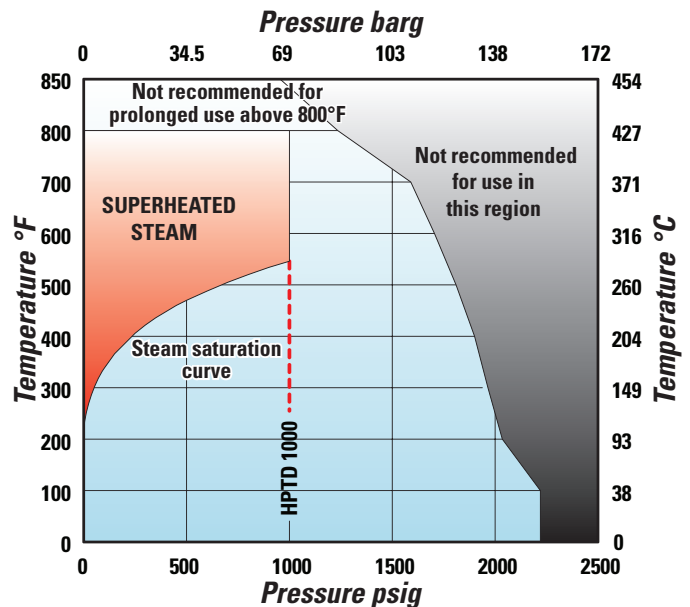



# VELAN THERMODYNAMIC STEAM TRAPS

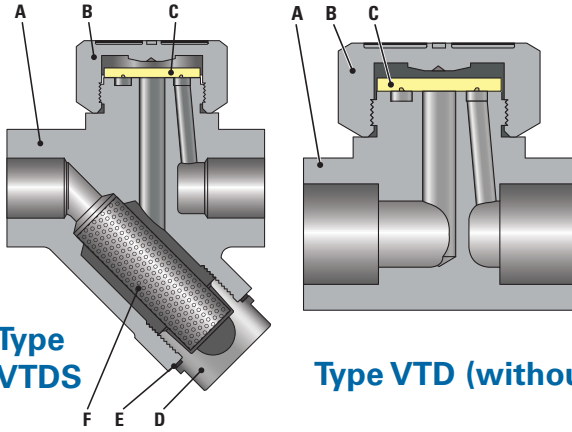

Type VTDS

Type VTD (without strainer element)

## STANDARD MATERIALS

PART	MATERIALS	
A	Body	Stainless steel CA40
B	Main cover	Stainless steel CA40
C	Floating disc	Stainless steel, hardened
D	Strainer cover	Stainless steel CA40
E	Strainer gasket	Stainless steel 304
F	Strainer element	Stainless steel 304

Note: Seat face – induction hardened.

## APPLICATIONS

Boiler headers, steam mains, branch lines, tracer lines, sterilizers, multi-platen presses, laundry ironers, rubber and plastic moulding equipment.

## CONNECTIONS:

- Screwed

## ENGINEERING DATA

TYPE	PRESSURE RANGE psig/barg	PMO psig/barg	MATERIAL	MAX TEMP °F/°C	MAX CAPACITY lb/hr/kg/hr
VTDS	5-600 (0.34-42)	600 (42)	SS CA40	800 426	1/2 & 3/4 1600 / 727
VTD				1 2300 / 1045	

PMA = Maximum allowable pressure: 914psig@100°F (63bar@38°C)

TMA = Maximum allowable temperature: 800°F (427°C)

Maximum cold hydrostatic test pressure: 1375psig (95bar)

TMO = Maximum operating temperature = TMA

PMO = Maximum operating pressure: (see Engineering data table)

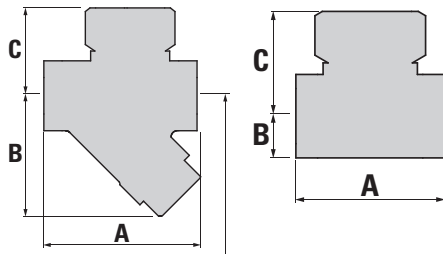

## DIMENSIONS AND WEIGHTS

TYPE	SIZE NPS/DN	A FACE TO FACE	B CENTER TO BOTTOM	C CENTER TO TOP	WEIGHT lb/kg
VTDS	1/2	3 5/32	2 1/2	1 13/16	2 1/2
	3/4	80	64	46	1.1
	20				
VTD	1	3 3/4	2 3/4	2 1/16	4 1/2
	25	96	70	52	2
VTDS	1/2	2 9/16	1 7/16	1 13/16	1 1/2
	3/4	65	36.5	46	0.7
	20				
VTD	1	3 3/8	1 7/8	2 1/16	3 1/2
	25	85	48	52	1.6

### Clearance for Strainer Removal:

1/2 & 3/4 – 3 1/2 in (90 mm) min.  
1 – 4 1/4 in (108 mm) min.

## CONDENSATE CAPACITY

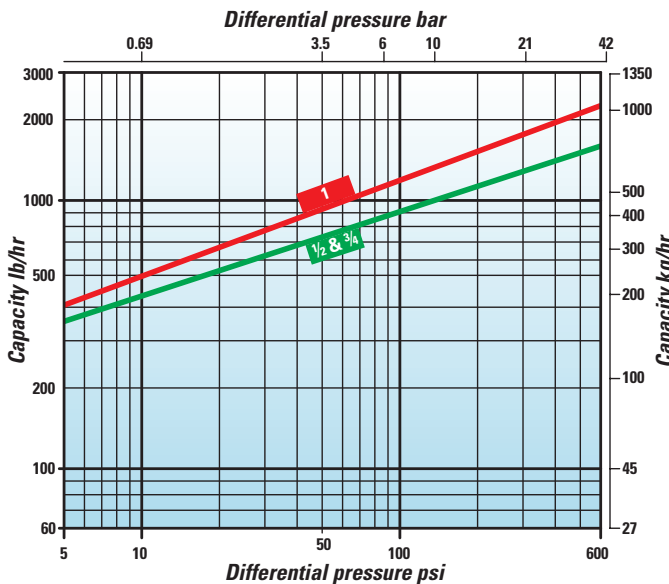

Maximum cold water capacity x 3.5

The performance graph indicates the continuous discharge capacities of condensate per hour at various pressure differentials across the trap.

## PRESSURE / TEMPERATURE LIMITS

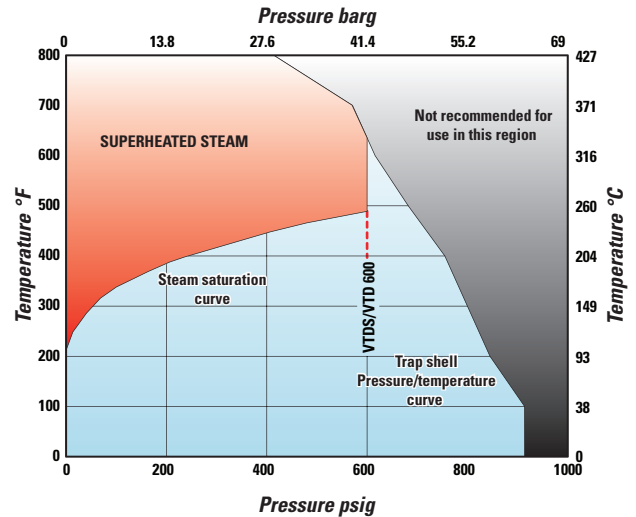

----- Pressure limit for trap type

# VELAN COMPRESSED AIR DRAIN TRAPS

- Type MFA/MFAS for pneumatic use:**
- power tools • blowing moulds • paint

**A complete unit: built-in strainer, check valve and air vent with dual inlet and outlet connections**

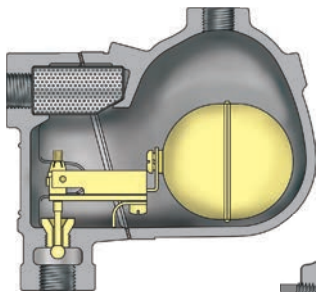

**Type MFA0**

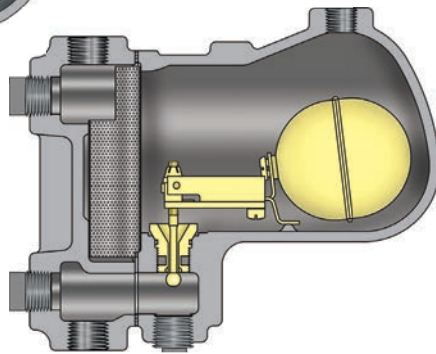

**Type MFA1 AND 2**

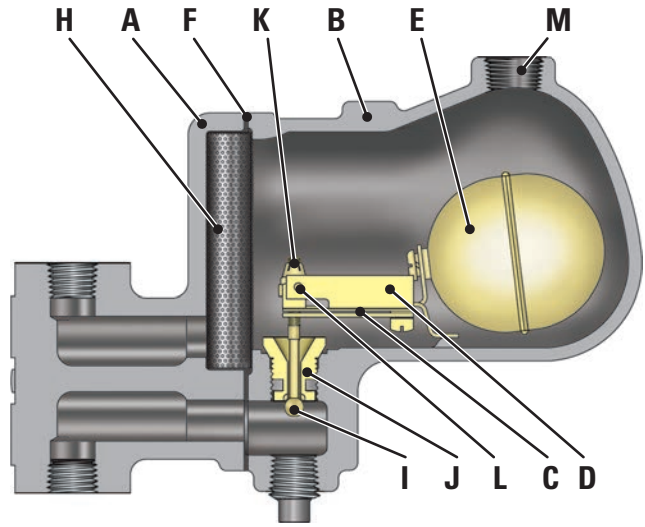

**Type MFAS**

## COMPRESSED AIR DRAINAGE

In much the same way as steam, but for quite different reasons, compressed air gives up moisture as it cools. The act of compression raises the temperature of the air and even when passed through an after-cooler, it still has heat to lose before reaching the point at which it is used.

Water vapor carried in compressed air condenses and collects in the bottom of receivers, tanks or separators, and in low points of compressed air lines. If such accumulations are not removed, the passing air will pick up moisture, which may cause rusting, sticking or spoiled work.

## TYPE MFA AND MFAS DESIGN FEATURES

The Velan Type MFA float trap automatically removes accumulated water from compressed air systems. Construction is similar to the Type MFT steam trap except that there is no thermostatic element. A boss is provided on top of the cover, tapped for a NPS  $\frac{3}{8}$  (DN 10) air circulating pipe which is necessary unless the trap is fitted directly under and so close to the drain point that air entering the trap can escape back through the inlet.

- **Stainless steel float and trim**
- **Simple Installation**  
Multiple inlet and outlet connections facilitate horizontal, vertical or angle installation.

- **Integral strainer**  
Stainless steel screens are integral to protect the trap operating mechanism from damage by dirt or scale. No extra fittings or installation costs are required. Free strainer area minimum 5 to 1. Perforation is 0.031" (0.8 mm).
- **Integral check valve operation**  
The main valve acts as a check valve preventing back flow.
- **Stainless steel pivots**  
Assure adequate protection against wear.
- **Seat CoCr alloy hardfaced**  
Increases resistance to the high degree of wear through velocity of flow, dirt and scale.
- **Freeze-proof installation**  
Freeze-proof without insulation – complete drainage when cold.

## APPLICATIONS

### Pneumatic power tool operation:

- Air operated chucks
- Air operated cutters

### Pneumatic blowing operation:

- Foundry mould blowing
- Paint shop spraying

# VELAN COMPRESSED AIR DRAIN TRAPS

## STANDARD MATERIALS

PART	MATERIALS	
	MFA-0,1,2	MFA-S
A Body	Cast iron Gr.250	Cast steel WCB
B Cover	Same as body material	
C Plate	Stainless steel 1/8" thick	
D Holder	Stainless steel	
E Float	Stainless steel	
F Cover gasket	Stainless steel with non-asbestos filler	
G Cover screw	High tensile steel Gr. S	
H Strainer	Stainless steel	
I Stem and ball	Stainless steel	
J Seat <sup>(1)</sup>	SS hardfaced with CoCr alloy	
K Self- locking adjusting nut	Stainless steel	
L Pivot plug	Stainless steel	
M Connection for balance pipe	3/8" NPT	

(1) MFA0: hardened seat.

## CONDENSATE CAPACITY

For capacities please contact Velan Valves Ltd.  
Tel: +44 116 269 5172 Fax: +44 116 269 3695

## ENGINEERING DATA

TYPE	PRESSURE RANGE psig/barg	PMO psig/barg	MATERIAL	ORIFICE in/mm
MFA0	0-125	125	Cast iron Gr.250	7/32 5.5
MFA1	0-8.5	8.5		
MFA2	0-200 0-14	200 14		
MFAS	0-150 0-10.5	150 10.5	Cast carbon steel WCB	
	0-230 0-16	230 16		
	0-300 0-21	300 21		

PMA = Maximum allowable pressure = PMO  
Maximum cold hydrostatic test pressure: 400psig (27.5bar) where PMO ≤ 200psig  
Twice PMO where PMO > 200psig  
PMO = Maximum operating pressure: (see Engineering data table)

## DIMENSIONS AND WEIGHTS

TYPE	SIZE NPS/DN	A HEIGHT	B (1) CENTER TO FACE	C (2) CENTER TO FACE	D LENGTH	WEIGHT LB/KG
MFA0	1/2 3/4 15 20	6 1/8 156	4 3/8 111	1 1/8 29	6 3/4 171	8.75 4

(1) Center of inlet to outlet face. (2) Center of outlet to inlet face.

### Type MFA0

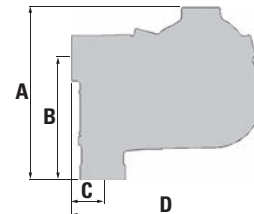

### Type MFA1, 2

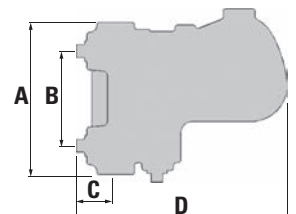

TYPE	SIZE NPS/DN	A (1) FACE TO FACE	B (2) CENTER TO CENTER	C (3) CENTER TO FACE	D LENGTH	WEIGHT LB/KG
MFA1	1/2 3/4 1 15 20 25	6 5/8 168	3 15/16 100	1 3/8 35	8 5/16 211	12 5.5
MFA2	3/4 1 20 25	7 11/16 195	4 3/4 121	1 7/16 37	9 3/8 238	15 7
MFA2	1 1/4 1 1/2 32 40	8 203	4 1/2 114	1 3/4 44	10 3/8 264	17 8

(1) Vertical connection. (2) Horizontal connection. (3) Center of vertical outlet to face of horizontal outlet.

### Type MFAS

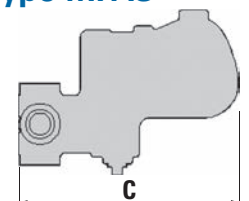

TYPE	SIZE NPS/DN	A FACE TO FACE			B CENTER TO BOTTOM	C CENTER TO TOP	WEIGHT LB/KG		
		SCR/SW	BW	FLG			SCR/SW	BW	FLG
MFAS	1/2 3/4 1 15 20 25	3 11/16 94	9 11/16 246	6 152	5 1/4 133	9 1/4 235	18 8	20 9	30 14

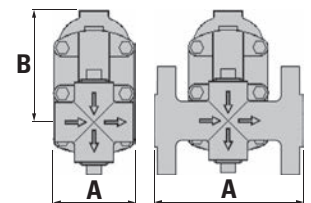

# INCLINED STRAINERS

## DESIGN FEATURES

- **Forged body (A)**  
Offers the advantages of high strength, structural integrity and reliability that make it an ideal choice for steam service.
- **Stainless steel screen (B)**  
Can withstand severe abrasive service and is carefully fitted to prevent leakage between the screen and body.

Screens are normally supplied in stainless steel with 0.031" (0.8 mm) holes (26% free area).

- **Easy internal maintenance**  
Strainers are extremely easy to clean. They may be blown down by simply removing the optional blow down plug or via a suitable valve fitted in its place.

## APPLICATIONS

Velan strainers protect steam traps, pumps, temperature and pressure regulators, gauges, instruments, air motors and other equipment from dirt, scale and other debris.

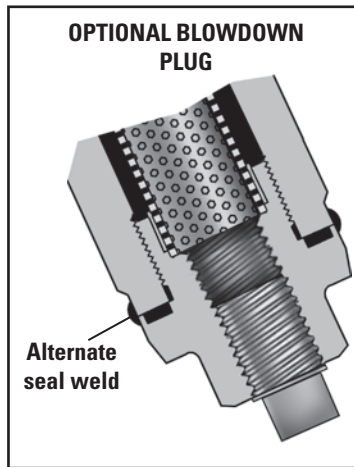
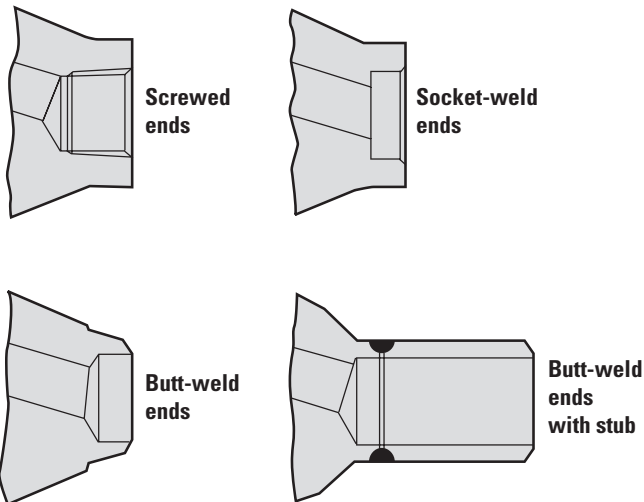
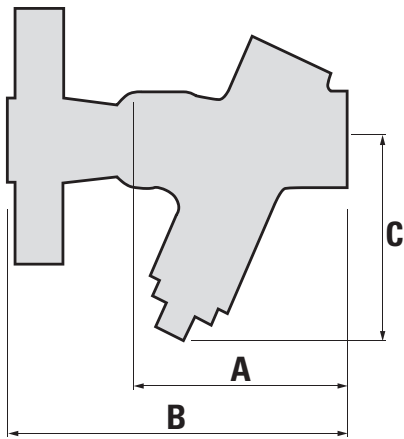
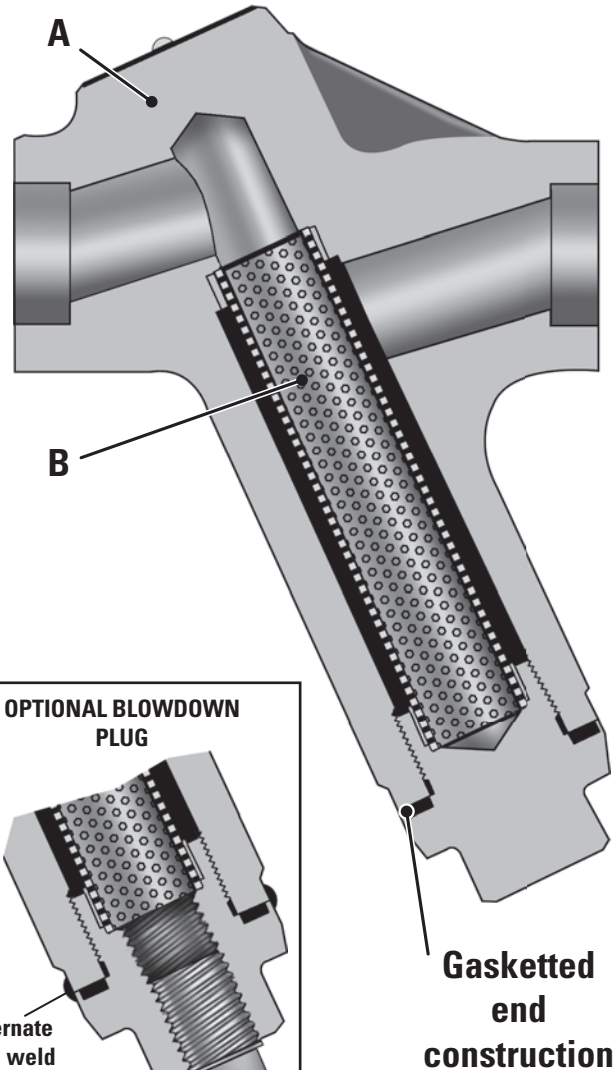

## DIMENSIONS & WEIGHTS

SIZE NPS DN	A FACE TO FACE				B BUTT WELD (STUBS) & FLANGED		C CENTER TO BOTTOM	
	SCR/SW		BW <sup>(1)</sup>		1500	2500	1500	2500
	1500	2500	1500	2500				
1/2	3 <sup>5</sup> / <sub>8</sub>	4 <sup>1</sup> / <sub>4</sub>	3 <sup>5</sup> / <sub>8</sub>	4 <sup>1</sup> / <sub>4</sub>	8 <sup>1</sup> / <sub>2</sub>	10 <sup>3</sup> / <sub>8</sub>	5	5
15	92	108	92	108	216	264	127	127
3/4	4 <sup>1</sup> / <sub>4</sub>	4 <sup>1</sup> / <sub>4</sub>	4 <sup>1</sup> / <sub>4</sub>	4 <sup>1</sup> / <sub>4</sub>	9	10 <sup>3</sup> / <sub>4</sub>	5 <sup>3</sup> / <sub>8</sub>	5 <sup>3</sup> / <sub>4</sub>
20	108	108	108	108	229	273	136	146
1	5 <sup>11</sup> / <sub>16</sub>	5 <sup>5</sup> / <sub>16</sub>	5 <sup>11</sup> / <sub>16</sub>	5 <sup>5</sup> / <sub>16</sub>	10	12 <sup>1</sup> / <sub>8</sub>	7	
25	144	135	144	135	254	308	178	
1 <sup>1</sup> / <sub>4</sub>	7	6 <sup>1</sup> / <sub>4</sub>	7	7	11	13 <sup>3</sup> / <sub>4</sub>	8 <sup>1</sup> / <sub>2</sub>	
32	178	159	178	178	297	349	216	
1 <sup>1</sup> / <sub>2</sub>	7	6 <sup>3</sup> / <sub>4</sub>	7	7	12	15 <sup>1</sup> / <sub>8</sub>	8 <sup>1</sup> / <sub>2</sub>	
40	178	171	178	178	305	384	216	
2	8	8	8	8	14 <sup>1</sup> / <sub>2</sub>	17 <sup>3</sup> / <sub>4</sub>	12 <sup>1</sup> / <sub>2</sub>	
50	203	203	203	203	368	451	318	

(1) These butt-weld dimensions do not comply with ASME/ANSI B16.10 (BS 2080). Velan reserves the right to vary specifications from time to time.

# ACCESSORIES

## VACUUM BREAKERS

Vacuum breakers should be installed wherever vacuum is created in pipelines or other equipment to ensure trouble free operation such as in heating coils for uninterrupted production and elimination of freezing.

The units are factory set to operate at 5 inHg (mercury) (0.17 barg) vacuum but can easily be reset to suit plant conditions.

Other applications include: unit heaters, cooking kettles, blast coils, and air-conditioning equipment.

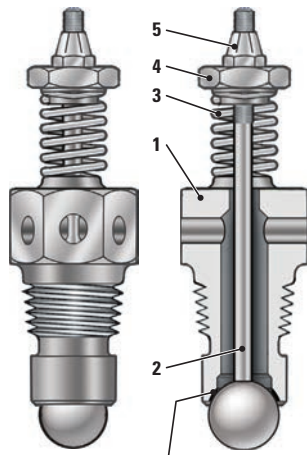

Seating face hardfaced with CoCr alloy and lapped with ball.

## STRAINER BLOWDOWN VALVE

A rugged stainless steel blowdown valve can be installed below the strainer in Velan steam traps as an optional extra. Body and valve are both stainless steel hardened. A forged steel globe, stop or needle valve can be fitted for high pressure operation or where greater integrity is required.

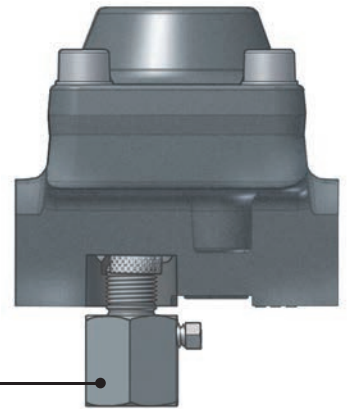

### Blowdown valve

#### Connections:

Inlet: NPS 3/8 (DN 10) male screwed NPT  
Outlet: NPS 1/4 (DN 6) female screwed NPT

## ENGINEERING DATA

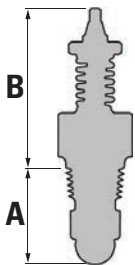

SIZE NPT THREAD NPS/DN	ORIFICE in/mm	A in/mm	B in/mm	WEIGHT oz/g
1/2 15	1/2 13	1 1/2 38	2 3/8 60	4 112
3/4 20	5/8 16	1 11/16 43	2 3/4 70	8 224
1 25	3/4 19	2 3/16 56	2 3/4 70	11 308

## STANDARD MATERIALS

PART	MATERIALS	SPECIFICATION
A Body	Stainless steel	BS 970-410S21
B Stem and ball	Stainless steel	Stem: BS 970-410S21 Ball: AISI 440C
C Compression spring	Stainless steel	BS 970-303S21
D Adjusting nut	Stainless steel	BS 970-410S21
E Self locking nut	Stainless steel	BS 970-304S15

## THERMOMETER

The Velan thermometer is actuated by a bimetallic helix shaped strip, which is enclosed in stainless steel. Its strong design will withstand adverse conditions and combines reliability with accuracy. The thermometer can be recalibrated on the spot and can be supplied with the following scales and ranges of operation:

### 32° – 572°F (0° – 300°C)

Case diameter: 1 3/4" (45 mm)  
Length: 1 1/2" (38 mm)  
Screwed connection: 1/4" NPT

### 32° – 932°F (0° – 500°C)

Case diameter: 2 3/4" (70 mm) Length: 3 3/4" (95 mm)  
Screwed connection: 1/4" NPT



## TEMPERATURE CONTROLLER

### Available for SSF, SPF, SF and SP

Velan steam traps are factory set to discharge condensate below saturated steam temperature, to save energy up to 30% and no further adjustment is required provided the trap is properly selected based on capacity.

To change the discharge temperature you must turn the regulating nut of the temperature controller towards the bottom of the trap to increase the differential temperature or away from the bottom of the trap to decrease the differential temperature. The movement of the regulating nut is transferred directly without friction to the trap valve and the free movement of the valve is increased or decreased accordingly. The result of the setting can be determined by checking the condensate's temperature with a Velan thermometer installed on the trap.

Other uses for the temperature controller are:

- excessive back pressure can be compensated for by turning the controller away from the trap bottom,
- if condensate is backed up, a faster rate of discharge is obtained by turning the controller away from the trap bottom, increasing the valve clearance,
- if the trap leaks steam, and the seating faces are not dirty or damaged, turning the controller towards the trap bottom will reduce the valve clearance thus slowing the trap response time, preventing steam loss.

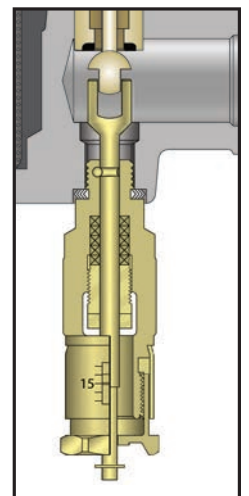

# VELAN STEAM TRAPS

# SAVE UP TO 30% ENERGY

\*Thermal Units are in Btu/lb (kcal/kg)

### Typical example:

Oil storage tank heating coil

### Required heat input:

2,000,000 Btu/h (504,000 kcal/h)

### Steam supply:

250 psig/406°F (17.2 barg/208°C)

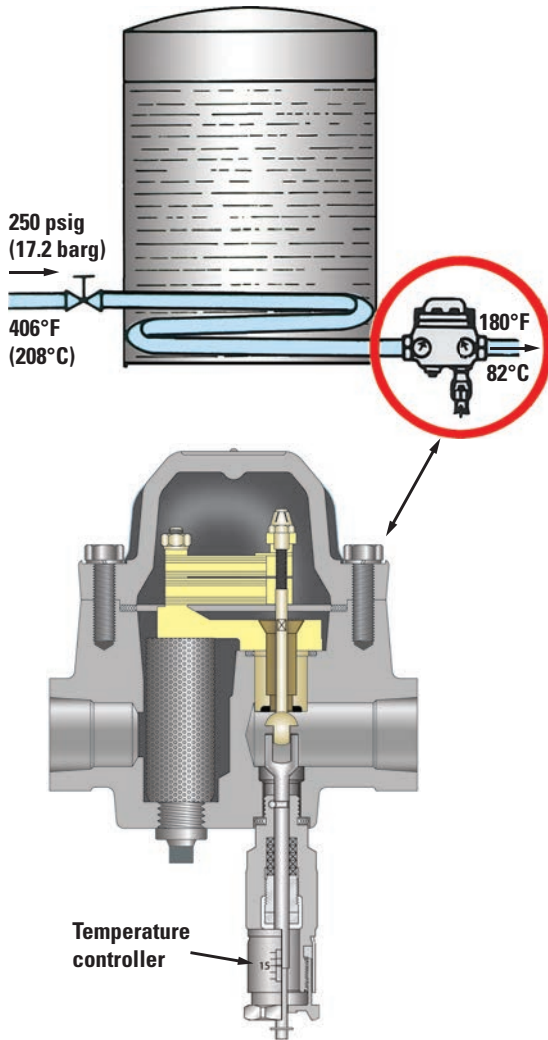

### ENERGY (STEAM) INPUT using conventional bucket, float, thermodynamic and bellows traps

Condensate is discharged as soon as it forms. The latent heat is extracted which, in our example, is 820 (456)\* per pound of condensate. Most of the sensible heat contained in the condensate 381.5 (212)\* or 32% is wasted.

#### STEAM DEMAND

$$= \frac{2,000,000 \text{ Btu/h}}{820 \text{ Btu/lb}} = 2,440 \text{ lb/h of steam}$$

$$\text{or}$$

$$= \frac{504,000 \text{ kcal/h}}{456 \text{ kcal/kg}} = 1,105 \text{ kg/h of steam}$$

Input per lb (kg)\*  
1201 (668)\* 100%

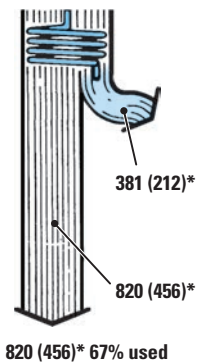

### ENERGY (STEAM) INPUT using Velan bimetallic traps

When using Velan bimetallic steam traps the discharge temperature of condensate is adjusted by a temperature controller and most of the sensible heat in the condensate is saved. Condensate is discharged at 180°F (82°C). 231.5 (129)\* [381.5-150 (212-83)\*] are available to re-evaporate part of lodged condensate 820 (456)\* required per lb (kg). 231.5 (129)\* will evaporate 29% into live steam. Heat is transferred to the oil efficiently and the heating process with high pressure condensate approaches heating with live steam.

#### STEAM DEMAND

$$= \frac{2,000,000 \text{ Btu/h}}{(820 + 231.5) \text{ Btu/lb}} = 1,900 \text{ lb/h of steam}$$

$$\text{or}$$

$$= \frac{504,000 \text{ kcal/h}}{(456 + 129) \text{ kcal/kg}} = 861 \text{ kg/h of steam}$$

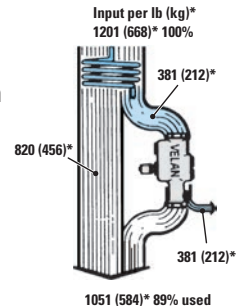

## VELAN SAVINGS

### STEAM SAVINGS

540 lb/h (244kg/h) [2,440-1,900 or 22% (1,105-861 or 22%)] 4,730,400 lb/year  
9,460 US \$ /year (at 2 US \$ for 1000 lb (455 kg) of steam)

Submit your steam trapping systems to Velan for free energy savings analysis

# COMPARISON OF PRINCIPLES OF OPERATION

## What design features to look for when selecting a steam trap

### FACTS FOR ESTIMATING TRAP VALUE

	 Velan Universal	 Thermostatic	 Float	 Bucket	 Thermodynamic
<b>Discharge valve actuated by:</b>	Heat of steam closes valve. Pressure opens valve when condensate cools down.	Only by heat.	Buoyancy and weight of float.	Closed by steam pressure. Opened by bucket weight and high levelage.	Closed by flow of hot condensate flashing into vapor. Opened by flow of cold condensate, no flashing.
<b>Perfect discharge when:</b>	Condensate cools down.	Selected trap size exactly conforms with working pressure and capacity.	Selected trap size exactly conforms with working pressure and capacity.	Selected trap size exactly conforms with working pressure and capacity.	Condensate temperature low.
<b>Trap selection:</b>	Universal sizes with large range.	According to capacity and temperature.	Certain after trial only due to small adaptability to pressure and capacity variations.	Certain after trial only due to small adaptability to pressure and capacity variations.	According to capacity and temperature.
<b>Incorrect selection effects:</b>	Universal sizes.	Low discharge capacity.	Steam loss. No flow or continuous flow.	Steam loss. No flow or continuous flow.	Low discharge capacity.
<b>Adjusting facilities for changed conditions:</b>	The only trap adjustable for specific conditions. No change of parts required.	None. New size required.	None. New size or type required. New valve orifice eventually.	None. New size or type required. New valve orifice eventually.	None. New size or type required.
<b>Ability for air elimination:</b>	Automatically with full trap capacity. No additional valve.	Automatic air elimination. No additional valve.	None. Additional cost for air-bypass valve and its installation.	Small. Extra cost for auxiliary air-bypass valve.	Automatically. No additional check valve.
<b>Ability to handle cold initial peakloads:</b>	Automatic cold water discharge with full capacity.	Automatic cold condensate discharge.	Intermittent discharge causes shocks.	Automatic cold condensate discharge.	Automatic cold condensate discharge.
<b>Ability to handle ordinary sediment and sludge, dirt conditions:</b>	Integral strainer in all units. Low first cost and cheapest installation.	None. Extra cost for strainer, additional fittings and installation.	None. Extra cost for strainer additional fittings and installation.	None. Extra cost for strainer. Clogging of bucket hole results in steam waste.	None. Extra cost for strainer and its installation.
<b>Absence of strainer often causes:</b>	Integral strainer in all units.	Smaller flow. Steam loss. Dirt getting into working parts and orifice.	Smaller flow. Steam loss. Dirt getting into working parts and orifice.	No flow. Steam waste. Buckets vent plugged or trap filled with dirt.	No flow. Continuous flow. Steam waste. Dirt, scale clogging seats and valve orifice.
<b>Ability to handle pressure variations:</b>	Good as bimetal follows saturated steam curve.	Good as bellow function of saturated steam.	Small. Pressure high: no flow. New valve orifice for raised pressure.	Small. Pressure high: no flow. New valve orifice for raised pressure.	Good. Depending on condensate temperature.
<b>Ability to handle variations in load:</b>	Good due to oversized orifice.	Depending on size of trap.	Small. Continuous discharge of trap too small.	Small. Continuous discharge of trap too small.	Depending on size of trap.
<b>Ability to close valve on hot water only to prevent steam loss:</b>	Yes. If required for 100% steam loss proof operation. Adjustability by temperature controller (optional).	Small.	None.	None.	Small.
<b>Ability to handle back pressure:</b>	Patented discharge valve operates as check valve. No extra cost for separate check valve involved.	None. Extra cost for check valve, additional fittings and their installation.	None. Extra cost for check valve. Steam loss if sudden or frequent drop in pressure.	None. Extra cost for check valve. Steam loss if sudden or frequent drop in pressure.	None. Extra cost for check valve. Steam loss if sudden or frequent drop in pressure.
<b>Installation position:</b>	The only all-position straight way type.	Only one position. Additional cost for fitting.	Only horizontal. Not suitable for marine service (float). Costly piping.	Only vertical. Costly piping. Not suitable for marine service (float).	Only horizontal. Costly piping.
<b>Installation cost:</b>	Lowest. Installed directly in pipe line without fittings. Integral strainer, check valve, air-bypass.	High. Additional cost for strainer, check valve.	High. Extra cost for additional fittings, strainer, check valve, air vent.	High. Extra cost for additional fittings, strainer, check valve, air vent.	Fair. Extra cost for additional fittings, strainer, check valve, air vent.
<b>Maintenance cost:</b>	Lowest. One size interchangeable. all over the plant. No fittings. Considerably reduced spare parts stock. Element cheap.	High. Many sizes, large stock of spare parts, fittings. Short life of flexible element.	High. Many sizes, large stock of spare parts, fittings. Short life of valve due to shocks.	Fair. Many sizes. Large stock of spare parts, fittings.	Fair. Many sizes. Large stock of spare parts, fittings. Delicate valve.
<b>Size, weight:</b>	Small, light weight	Fair.	Large, heavy. Weight up to 80 lb (36 kg).	Medium. For high capacity weight up to 80 lb (36 kg).	Fair.
<b>Freeze-proof operation:</b>	100% freeze-proof in vertical position. Valve widely open.	Special types. Not when trap fails and closes valve.	None.	None.	Yes.
<b>Ability to control temperature in heat process:</b>	Automatic temperature control for specific requirements; optional.	None.	Precautions necessary.	Precautions necessary.	None.
<b>Superheated steam:</b>	Highly recommended up to 1100°F (593°C). Valve tightly closed or high temperature.	Good only up to 500°F (260°C). Expensive stainless steel bellows.	Fair. Danger of re-evaporation body-water and tremendous loss of steam.	Fair. Danger of re-evaporation of body-water and tremendous loss of steam.	Fair but always small steam escapes.

NOTE: The information on this page is general in nature and not intended to show the exact design or performance of any specific manufacturer. The technical comparisons are not intended to downgrade other trap types but to compare their features and operating principles with the Velan steam trap.

# SELECTION AND SIZING

## DETERMINING THE CAPACITY OF STEAM TRAPS

To determine the discharge capacity of steam traps, the following factors must be taken into consideration:

- **Pressure differential between inlet and outlet**
- **Diameter of orifice**
- **Discharge temperature of condensate**

The condensate capacity charts given for each type are based on tests under working conditions and represent the actual maximum performance with condensate at 40°F (22°C) below saturated steam temperature, which is the standard setting.

Traps will normally commence opening at 15°F (8°C) below saturated steam temperature, but this can be varied if required.

If the condensate is cooler, when starting up from cold for instance, the capacities will be increased considerably. A small increase in the setting of the trap will result in a closer temperature differential and an increase in capacity.

A decrease in setting will provide an element of temperature control, discharging cooler condensate at predetermined temperatures, with reduced flow rates.

## HOW TO SELECT THE SIZE AND TYPE OF TRAP FOR A GIVEN DUTY

Calculate or estimate the maximum amount of steam condensate in lb/h or kg/h and multiply by the appropriate safety factor shown in the **Table of Safety Factors** (see bottom page 51).

Ascertain the minimum pressure at the trapping point and the maximum pressure liable to occur at the outlet side of the trap. The difference of these two gives the Pressure Differential.

**There are four possible arrangements for the trap, with corresponding variations in the Pressure Differential (Example: with steam at 20 psig (1.38 barg)):**

	<b>Imperial</b>	<b>Metric</b>
<b>(A) Trap discharging to atmosphere:</b>		
Pressure on outlet of trap	0	0
The Pressure Differential	= 20 psig	1.38 barg
<b>(B) Trap discharging into a closed return main</b>		
with a positive backpressure of:	5 psig	0.34 barg
Pressure at trap outlet	20 - 5 psig	1.38 - 0.34 barg
The Pressure Differential	= 15 psig	1.04 barg
<b>(C) Trap discharging into overhead return main, open to atmosphere, 6ft (1.8m) above the trap. The condensate therefore has to be lifted and causes a back pressure of approximately 1 psi for every 2 ft of lift (0.11 barg per meter).</b>		
	20 - 6/2	1.39 - 0.11 x 1.8
	20 - 3	1.38 - 0.198
The Pressure Differential	= 17 psig	1.18 barg
<b>D) Trap discharge into a vacuum, such as a condenser.</b>		
In this case, as the trap pressure is above atmospheric pressure the condenser pressure must be added to obtain the Pressure Differential. Condenser pressures normally are given by vacuum gauges in inches of mercury (inHg) and/or barg. When calculating in imperial units the inHg should be converted to <b>psi</b> as follows: 2 inHg corresponds to approximately 1 <b>psi</b> .		
If the vacuum gauge reads 16 inHg (-0.54 barg):	20 + 16/2	1.38 + 0.54
	20 + 8	+1.92 barg
The Pressure Differential	= 28 psig	

Having calculated the Pressure Differential refer to the individual Performance Charts and select a trap suitable for the estimated discharge at the Pressure Differential.



# STEAM TABLES

GAUGE PRESSURE		ABSOLUTE PRESSURE		SATURATION TEMPERATURE (ts)		SPECIFIC ENTHALPY				SPECIFIC VOLUME STEAM		
						WATER Sensible heat (hf) kJ/kg	EVAPORATION Latent heat (hfg) kJ/kg	WATER Sensible heat (hf) Btu/lb	EVAPORATION Latent heat (hfg) Btu/lb	Vg		
barg	psig	bar.a	psi.a	°C	°F							m³/kg
VACUUM	-0.96	28.4	0.05	0.725	32.9	91	138	2423	59	1042	28.2	452
	-0.91	27.0	0.1	1.45	45.8	114	192	2392	82	1029	14.7	236
	-0.86	25.5	0.15	2.18	54.0	129	226	2373	97	1020	10.0	160
	-0.81	24	0.2	2.90	60.1	140	251	2358	108	1014	7.65	123
	-0.76	22.5	0.25	3.63	65.0	149	272	2346	117	1009	6.20	99.3
	-0.71	21.1	0.3	4.35	69.1	156	289	2336	124	1004	5.23	83.8
	-0.66	19.6	0.35	5.08	72.7	163	304	2327	131	1000	4.53	72.6
	-0.61	18.1	0.4	5.80	75.9	169	318	2319	137	997	3.99	63.9
	-0.56	16.6	0.45	6.53	78.7	174	330	2312	142	994	3.58	57.3
	-0.51	15.1	0.5	7.25	81.3	178	341	2305	147	991	3.24	51.9
	-0.46	13.7	0.55	7.98	83.7	183	351	2299	151	988	2.96	47.4
	-0.41	12.2	0.6	8.7	85.9	187	360	2294	155	986	2.73	43.7
	-0.36	10.7	0.65	9.43	88.0	190	369	2288	159	984	2.54	40.7
	-0.31	9.24	0.7	10.2	90.0	194	377	2283	162	982	2.37	38.0
	-0.26	7.77	0.75	10.9	91.8	197	384	2279	165	980	2.22	35.6
-0.21	6.29	0.8	11.6	93.5	200	392	2274	169	978	2.09	33.5	
-0.16	4.81	0.85	12.3	95.1	203	399	2270	172	976	1.97	31.6	
-0.11	3.34	0.9	13.1	96.7	206	405	2266	174	974	1.87	30.1	
-0.06	1.86	0.95	13.8	98.2	209	411	2262	177	972	1.78	28.5	
-0.01	0.38	1.0	14.5	99.6	211	418	2258	179	971	1.69	27.1	
0	0	1.013	14.696	100	212	419	2257	180	970	1.67	26.8	
0.1	1.45	1.11	16.1	103	217	430	2250	185	967	1.53	24.5	
0.2	2.90	1.21	17.5	105	221	441	2243	190	964	1.41	22.6	
0.3	4.35	1.31	19.0	107	225	450	2237	194	962	1.31	21.0	
0.4	5.8	1.41	20.5	110	230	460	2231	198	959	1.23	19.7	
0.5	7.25	1.51	21.9	112	234	468	2226	201	957	1.15	18.4	
0.6	8.70	1.61	23.4	114	237	476	2220	205	954	1.08	17.3	
0.7	10.2	1.71	24.8	115	239	484	2215	208	952	1.02	16.3	
0.8	11.6	1.81	26.3	117	243	492	2211	212	951	0.971	15.6	
0.9	13.1	1.91	27.7	119	246	499	2206	215	948	0.923	14.8	
1.0	14.5	2.01	29.2	120	248	506	2201	218	946	0.881	14.1	
1.1	16.0	2.11	30.6	122	252	512	2197	220	945	0.841	13.5	
1.2	17.4	2.21	32.1	123	253	519	2193	223	943	0.806	12.9	
1.3	18.9	2.31	33.5	125	257	525	2189	226	941	0.773	12.4	
1.4	20.3	2.41	35.0	126	259	531	2185	228	939	0.743	11.9	
1.5	21.8	2.51	36.4	128	262	536	2181	230	938	0.714	11.4	
1.6	23.2	2.61	37.9	129	264	542	2177	233	936	0.689	11.0	
1.7	24.7	2.71	39.3	130	266	547	2174	235	935	0.665	10.7	
1.8	26.1	2.81	40.8	131	268	552	2170	237	933	0.643	10.3	
1.9	27.6	2.91	42.2	133	271	557	2167	240	932	0.622	9.96	
2.0	29.0	3.01	43.7	134	273	562	2163	242	930	0.603	9.66	
2.2	31.9	3.21	46.6	136	277	572	2157	246	927	0.568	9.1	
2.4	34.8	3.41	49.5	138	280	581	2151	250	925	0.536	8.59	
2.6	37.7	3.61	52.4	140	284	589	2145	253	922	0.509	8.15	
2.8	40.6	3.81	55.3	142	288	597	2139	257	920	0.483	7.74	
3.0	43.5	4.01	58.2	144	289	605	2133	260	917	0.461	7.38	
3.2	46.4	4.21	61.1	146	293	613	2128	264	915	0.44	7.05	
3.4	49.3	4.41	64.0	147	297	620	2123	267	913	0.422	6.76	
3.6	52.2	4.61	66.9	149	298	627	2118	270	911	0.405	6.49	
3.8	55.1	4.81	69.8	150	302	634	2113	273	908	0.389	6.23	
4.0	58.0	5.01	72.7	152	304	641	2108	276	906	0.374	5.99	
4.2	60.9	5.21	75.6	153	307	647	2104	278	905	0.361	5.78	
4.4	63.8	5.41	78.5	155	309	653	2099	281	902	0.348	5.57	
4.6	66.7	5.61	81.4	156	313	659	2095	283	901	0.336	5.38	
4.8	69.6	5.81	84.3	158	315	665	2090	286	899	0.325	5.21	
5.0	72.5	6.01	87.2	159	316	671	2086	289	897	0.315	5.01	
5.5	79.8	6.51	94.4	162	324	685	2076	295	893	0.292	4.68	
6.0	87.0	7.01	102	165	329	698	2066	300	888	0.272	4.36	
6.5	94.3	7.51	109	168	333	710	2057	305	884	0.255	4.09	
7.0	102	8.01	116	171	338	721	2048	310	880	0.24	3.84	
7.5	109	8.51	123	173	343	733	2039	315	877	0.227	3.64	
8.0	116	9.01	131	175	347	743	2031	319	873	0.215	3.44	
8.5	123	9.51	138	178	351	753	2023	324	870	0.204	3.27	
9.0	131	10.0	145	180	354	763	2015	328	866	0.194	3.11	
9.5	138	10.5	152	182	360	773	2008	332	863	0.185	2.96	
10.0	145	11.0	160	184	363	782	2000	336	860	0.177	2.84	
10.5	152	11.5	167	186	367	790	1993	340	857	0.171	2.74	
11.0	160	12.0	174	188	370	798	1986	344	854	0.163	2.61	
11.5	167	12.5	181	190	374	807	1979	347	851	0.157	2.51	
12.0	174	13.0	189	192	376	815	1973	350	848	0.151	2.42	
12.5	181	13.5	196	193	379	823	1966	354	845	0.146	2.34	
13.0	189	14.0	203	195	383	830	1960	357	843	0.141	2.26	
13.5	196	14.5	210	197	385	838	1953	360	840	0.136	2.18	
14.0	203	15.0	218	198	388	845	1947	363	837	0.132	2.11	
14.5	210	15.5	225	200	392	852	1941	366	834	0.128	2.05	
15.0	218	16.0	232	202	394	859	1935	369	832	0.124	1.99	

# STEAM TABLES

GAUGE PRESSURE		ABSOLUTE PRESSURE		SATURATION TEMPERATURE (ts)		SPECIFIC ENTHALPY				SPECIFIC VOLUME STEAM	
barg	psig	bar.a	psi.a	°C	°F	WATER Sensible heat (hf) kJ/kg	EVAPORATION Latent heat (hfg) kJ/kg	WATER Sensible heat (hf) Btu/lb	EVAPORATION Latent heat (hfg) Btu/lb	Vg	
										m³/kg	ft³/lb
15.5	225	16.5	239	203	397	866	1929	372	829	0.120	1.92
16.0	232	17.0	247	204	399	872	1923	375	827	0.117	1.87
16.5	239	17.5	254	205	401	879	1918	378	824	0.114	1.83
17.0	247	18.0	261	207	405	885	1912	381	822	0.110	1.76
17.5	254	18.5	268	209	408	891	1907	383	820	0.108	1.73
18.0	261	19.0	276	210	410	897	1901	386	817	0.105	1.68
18.5	268	19.5	283	211	412	903	1896	388	815	0.103	1.65
19.0	276	20.0	290	213	415	909	1890	391	813	0.100	1.6
19.5	283	20.5	297	214	417	915	1885	393	810	0.0972	1.56
20.0	290	21.0	305	215	419	920	1880	396	808	0.0949	1.52
21.0	305	22.0	319	217	423	931	1870	400	804	0.0906	1.45
22.0	319	23.0	334	220	428	942	1860	405	800	0.0868	1.39
23.0	334	24.0	348	222	432	952	1850	409	795	0.0832	1.33
24.0	348	25.0	363	224	435	962	1841	414	792	0.0797	1.28
25.0	363	26.0	377	226	439	972	1831	418	787	0.0768	1.23
26.0	377	27.0	392	228	442	982	1822	422	783	0.0740	1.19
27.0	392	28.0	406	230	446	991	1813	426	779	0.0714	1.14
28.0	406	29.0	421	232	450	1000	1804	430	776	0.0689	1.1
29.0	421	30.0	435	234	453	1009	1796	434	772	0.0666	1.07
30.0	435	31.0	450	236	457	1017	1787	437	768	0.0645	1.03
31.0	450	32.0	464	238	460	1026	1779	441	765	0.0625	1
32.0	464	33.0	479	239	462	1034	1770	445	761	0.0605	0.97
33.0	479	34.0	493	241	466	1042	1762	448	758	0.0587	0.94
34.0	493	35.0	508	243	469	1050	1754	451	754	0.0571	0.915
35.0	508	36.0	522	244	471	1058	1746	455	751	0.0554	0.887
36.0	522	37.0	537	246	475	1066	1737	458	747	0.0539	0.863
37.0	537	38.0	551	247	477	1073	1730	461	744	0.0524	0.839
38.0	551	39.0	566	249	480	1080	1722	464	740	0.0510	0.817
39.0	566	40.0	580	250	482	1087	1714	467	737	0.0498	0.798
40.0	580	41.0	595	252	486	1095	1706	471	733	0.0485	0.777
41.0	595	42.0	609	253	487	1102	1699	474	730	0.0473	0.758
42.0	609	43.0	624	255	491	1108	1691	476	727	0.0461	0.738
43.0	624	44.0	638	256	493	1115	1684	479	724	0.0451	0.722
44.0	638	45.0	653	258	496	1122	1676	482	721	0.0441	0.706
45.0	653	46.0	667	259	498	1129	1669	485	718	0.0431	0.690
46.0	667	47.0	682	260	500	1135	1662	488	715	0.0421	0.674
47.0	682	48.0	696	261	502	1142	1654	491	711	0.0412	0.660
48.0	696	49.0	711	263	505	1148	1647	494	708	0.0403	0.646
49.0	711	50.0	725	264	507	1155	1640	497	705	0.0395	0.633
50.0	725	51.0	740	265	509	1161	1633	499	702	0.0386	0.618
52.0	754	53.0	769	268	514	1173	1619	504	696	0.0371	0.594
54.0	783	55.0	798	270	518	1185	1605	509	690	0.0356	0.570
56.0	812	57.0	827	272	522	1197	1591	515	684	0.0343	0.549
58.0	841	59.0	856	272	525	1208	1577	519	678	0.0330	0.529
60.0	870	61.0	885	277	531	1219	1564	524	672	0.0319	0.511
62.0	899	63.0	914	279	534	1230	1551	529	667	0.0308	0.493
64.0	928	65.0	943	281	538	1241	1538	534	661	0.0297	0.476
66.0	957	67.0	972	283	541	1251	1525	538	656	0.0288	0.461
68.0	986	69.0	1001	285	545	1262	1512	543	650	0.0278	0.445
70.0	1015	71.0	1030	287	549	1272	1499	547	644	0.0270	0.432
72.0	1044	73.0	1059	289	552	1283	1486	552	639	0.0261	0.418
74.0	1073	75.0	1088	291	556	1293	1473	556	633	0.0253	0.405
76.0	1102	77.0	1117	292	559	1303	1460	560	628	0.0246	0.394
78.0	1131	79.0	1146	294	561	1312	1447	564	622	0.0239	0.383
80.0	1160	81.0	1175	296	565	1322	1435	568	617	0.0232	0.372
82.0	1189	83.0	1204	298	568	1331	1422	572	611	0.0226	0.362
84.0	1218	85.0	1233	299	570	1341	1410	576	606	0.0219	0.351
86.0	1247	87.0	1262	301	574	1350	1398	580	601	0.0213	0.341
88.0	1276	89.0	1291	302	576	1359	1385	584	595	0.0208	0.333
90.0	1305	91.0	1320	304	579	1368	1368	588	590	0.0202	0.324
92.0	1334	93.0	1349	305	581	1377	1360	592	585	0.0197	0.316
94.0	1363	95.0	1378	307	585	1386	1348	596	580	0.0192	0.308
96.0	1392	97.0	1407	309	588	1395	1336	600	574	0.0187	0.300
98.0	1421	99.0	1436	310	590	1404	1323	604	569	0.0183	0.293
100.0	1450	101	1465	312	594	1412	1311	607	564	0.0178	0.285
110.0	1595	111	1610	319	606	1454	1249	625	537	0.0158	0.253
120.0	1741	121	1755	325	617	1495	1188	643	511	0.0141	0.226
130.0	1886	131	1900	331	628	1535	1125	660	484	0.0126	0.202
140.0	2031	141	2045	337	639	1575	1060	677	456	0.0114	0.183
150.0	2176	151	2190	343	649	1614	994	694	427	0.0102	0.163
160.0	2321	161	2335	348	658	1654	925	711	398	0.00922	0.148
170.0	2466	171	2480	353	667	1694	850	728	365	0.00829	0.133
180.0	2611	181	2625	357	675	1736	769	746	331	0.00743	0.119
190.0	2756	191	2770	362	684	1782	679	766	292	0.00660	0.106
200.0	2901	201	2915	366	691	1833	562	788	242	0.00577	0.0924

# HOW TO ORDER

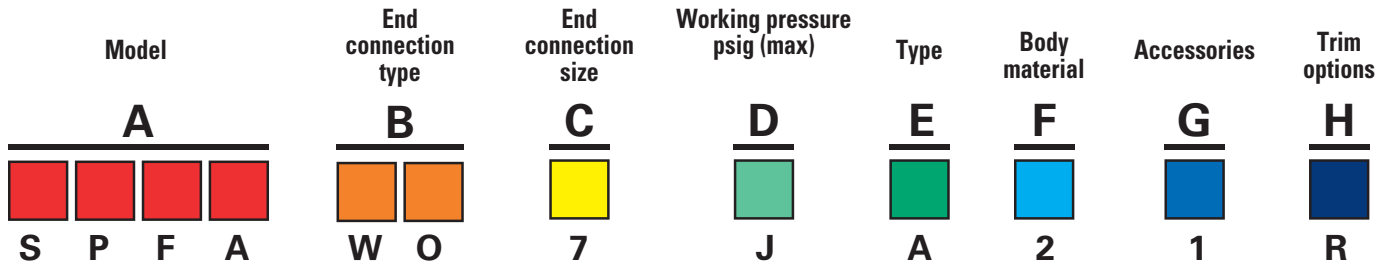

Above example: SPFA (0, 1, 2, & 3), NPS 1½ (DN 40) socket-weld connection, maximum 350 psig, in carbon steel, with temperature controller and Truflex trim.

The figure numbers shown on this key are designed to cover essential features of Velan steam traps. Please use figure numbers to ensure prompt and accurate processing of your order. A detailed description must accompany any special orders.

A MODEL				
HPTD - HPTD	MFA5 - MFA5	TS01 - TS		
MFT0 - MFT0	MFTS - MFTS	TSFO - TSF		
MFT1 - MFT1	MFAS - MFAS	USTO - UST		
MFT2 - MFT2	N000 - N	VBO0 - vacuum breaker		
MFT3 - MFT3	QC00 - Q	VTDO - VTD		
MFT4 - MFT4	SFO0 - SF	VTDS - VTDS		
MFT5 - MFT5	SSFO - SSF	VTSO - VTS		
MFA0 - MFA0	SPFA - SPF 0, 1, 2 & 3			
MFA1 - MFA1	SPFB - SPF 4, 5, 6 & 7			
MFA2 - MFA2	SPOO - SP 6, 7 & 8			
B END CONNECTION TYPE				
BUTT-WELD:	FLANGED:	FLANGED:		
AO - SCH. 40	(Raised face)	FJ - BST "A"		
BO - SCH. 80	FA - ASME 150	FK - BST "D"		
CO - SCH. 160	FB - ASME 300	FL - BST "E"		
EO - SCH. XXS	FC - ASME 600	FM - BST "F"		
DO - Combination ends	FD - ASME 1500	FN - BST "H"		
WO - Socket-weld	FE - ASME 2500	FO - BST "J"		
XO - Special ends	FF - PN 10/16	FP - BST "K"		
SCREWED:	FG - PN 25/40	FQ - BST "R"		
NO - NPT	FH - PN 64	FR - BST "S"		
SO - BSPP	FI - PN 100	FS - BST "T"		
TO - BSPT	FT-PN 160	FX - Special		
C END CONNECTION SIZE - NPS (DN)				
0 - Special	3 - ½ (15)	6 - 1 ¼ (32)	9 - 2 ½ (65)	14 - 6 (150)
1 - ¼ (8)	4 - ¾ (20)	7 - 1 ½ (40)	10 - 3 (80)	
2 - ¾ (10)	5 - 1 (25)	8 - 2 (50)	12 - 4 (100)	

D WORKING PRESSURE PSIG (MAXIMUM)					
A - 15	F - 150	L - 600	R - 250	W - 1000	AD - 450
B - 25	G - 200	M - 1500	S - 900	X - Special	
C - 50	H - 300	N - 2500	T - 675	Y - 30	
D - 100	J - 350	P - 40	U - 230	Z - 2600	
E - 125	K - 400	Q - 120	V - 485	AC - 4000	
E TYPE					
A - Steam traps			G - Freeze protector		
B - Trap with integral bypass			H - Piping King (isolating valve)		
C - Piping King (no bypass)			I - Trap + 2 PBV double isolation		
D - Piping King (with bypass)			J - Trap + 3 PBV bypass unit		
E - Air trap			K - Trap + 1 PBV single isolation		
F - Vacuum breaker			X - Special		
F BODY MATERIAL					
1 - Special		6 - Chr. moly., alloy steel, F22/WC9			
2 - Carbon steel, A105/WCB		7 - Cast iron			
4 - Chr. moly., alloy steel, F91/C12A		8 - Bronze			
5 - Chr. moly., alloy steel, F11/WC6		9 - Stainless steel			
G ACCESSORIES					
0 - None		5 - Combination			
1 - Temperature controller		6 - Special			
2 - Strainer blowdown valve		7 - Sight glass			
3 - Test valve		8 - Thermometer			
4 - Strainer plug		9 - Separate strainer			
H TRIM OPTIONS					
A - Special element		D - Combination			
B - Welded seat		R - Truflex			
C - Screwed seat		O - None			

**Notes:**

- For a more detailed list of available trims, contact the factory or visit our web site at [www.velan.com](http://www.velan.com)
- ANSI class trap – suffix fig no. with hyphen class rating eg: N000W05MA20R – 1500 = NPS 1 (DN 25) socket-weld N trap 1500psig operating pressure with shell rating to ANSI class 1500.
- Pipe connectors for universal steam trap Type UST available in sizes NPS ½, ¾, and 1 (DN 15, 20, and 25) on request.

## TABLE OF SAFETY FACTORS

TYPE OF EQUIPMENT	SAFETY FACTOR
Coils (blast, unit heaters), air heaters, dryers, air conditioning plant:	
(a) Using inside air.....	2
(b) Using outside air.....	3
Kilns, drying room ovens, steam mains, paper machines, drying cylinders, autoclaves, platens, laundry ironers, sterilisers.....	3
Heat exchangers calorifiers, jacketed pans, hot water heaters, temperature control and where throttling steam controls are used.....	3-4

**Example:** A trap is required for a heat exchanger which is supplied with steam at 100 psig (7 barg) and has a consumption of 1500 lb (680 kg) steam per hour. The trap discharges to closed return main at a pressure of 10 psig (0.7 barg). The safety factor for this type application is 2.

	Imperial	Metric
Trap inlet pressure	100 psig	7 barg
Trap outlet pressure	10 psig	0.7 barg
Differential pressure	90 psig	6.2 barg
Steam consumption	1,500 lb/h	680 kg/h
Applying safety factor of 2	3,000 lb/h	1,365 kg/h

**Therefore select trap from the individual Performance charts capable of discharging 3,000 lb/h (1,365 kg/h) at a differential pressure of 90 psig (6.3 barg).**

*The most comprehensive line of industrial forged and cast steel gate, globe, check, ball, butterfly, and knife gate valves and steam traps.*

**ASME pressure classes 150–4500 in carbon, alloy, and stainless steel**

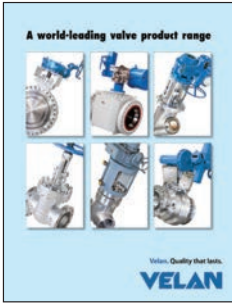

**BRO-FLB**



**SAS-FLB**

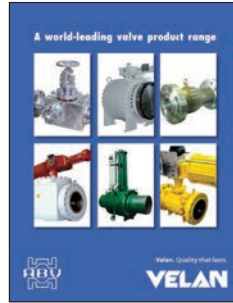

**ABV-FLB**

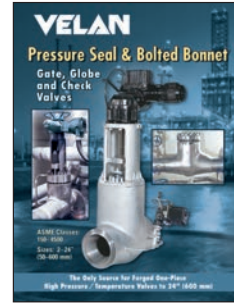

**VEL-PS**

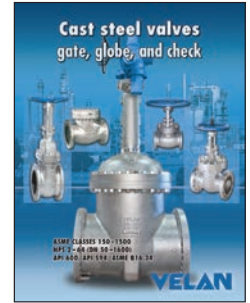

**CAT-CSV**

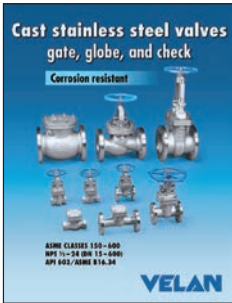

**CAT-CSSV**

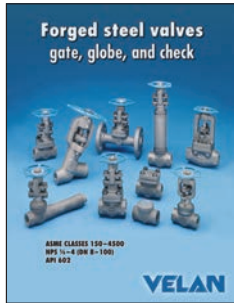

**CAT-SFV**

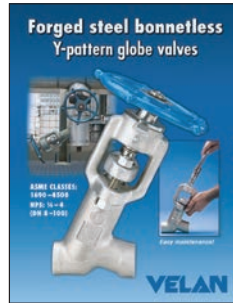

**CAT-BG**

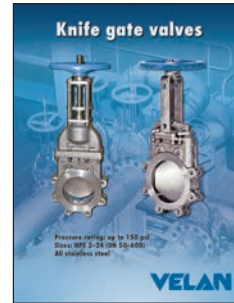

**CAT-KGV**



**CAT-DPCV**

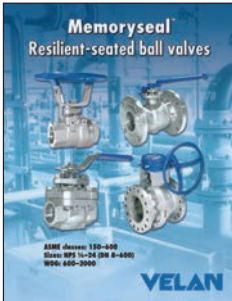

**CAT-BV**

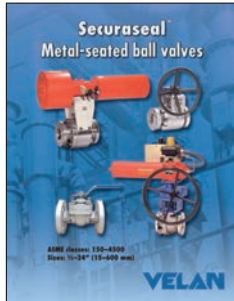

**VEL-MS**



**CAT-PBV**

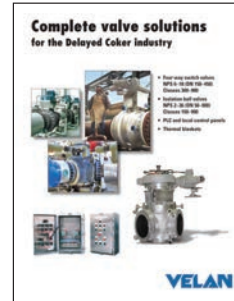

**BRO-CBV**

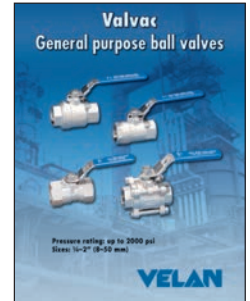

**CAT-GPBV**

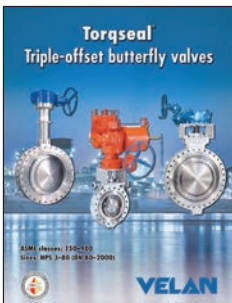

**CAT-BF**



**SAS-CCV**

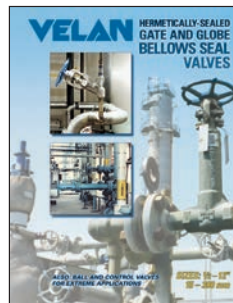

**VEL-BS**

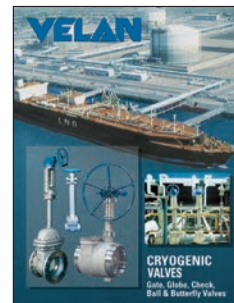

**VEL-CRYO**

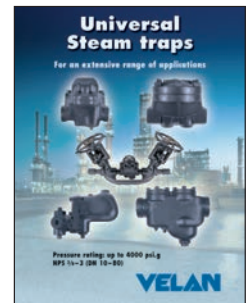

**CAT-ST**

Headquartered in Montreal, Canada, Velan has several international subsidiaries. For general inquiries:

**Velan head office**

7007 Côte de Liesse, Montreal, QC H4T 1G2 Canada

Tel: +1 514 748 7743 Fax: +1 514 748 8635

Check our website for more specific contact information.

[www.velan.com](http://www.velan.com)

CAT-ST-03-14

Printed in Canada

© 2014 Velan Inc., Montreal, QC, Canada. All rights reserved. The contents hereof are confidential and proprietary to Velan. Any unauthorized reproduction or disclosure, in whole or in part, is strictly prohibited. The material in this catalog is for general information only and shall not be used for specific performance data and material selection without first consulting Velan. Velan reserves the right to change this information without notice. Velan does not accept any liability or damages arising from the use of information in this catalog. Velan Valves, Velan, Memoryseal, Torqseal, Velflex, Adaxie, and RAMA are trademarks or registered trademarks of Velan Inc. and/or another Velan company. Stellite® is a registered trademark of Kennametal Stellite™, a wholly owned subsidiary of Kennametal Inc. All other trademarks and registered trademarks are owned by their respective companies.

**VELAN**