

COMPARISON SHEET

VELAN STEAM TRAP VS. INVERTED BUCKET DESIGN

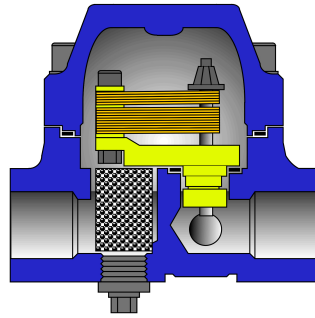

Velan Steam Trap

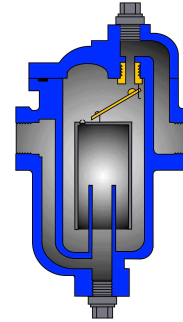

Inverted Bucket Steam Trap

<p>RAPID AIR VENTING</p> <p>At startup, the Velan steam trap is fully open, venting air quickly and efficiently. This results in a faster startup with fewer plant personnel required to supervise venting of main lines during warm-up. There is no external blow down needed to start up the steam line.</p>	<p>POOR AIR VENTING</p> <p>The inverted bucket steam trap has poor air handling characteristics. Due to the fact that the orifice in the bucket must be restricted so it will float shut when live steam enters, it has difficulty passing the tremendous amount of air on start up. There may be external blow down needed to start up the steam line.</p>
<p>STELLITE 6 TRIM STANDARD</p> <p>All Velan steam traps are fitted with Stellite 6® seat facings to resist wear by high velocity flow, dirt and scale. Stellite 6® has 3 times the wear resistance of induction hardened stainless steel.</p>	<p>NO ALLOY TRIM AVAILABLE</p> <p>Inverted bucket steam traps are not available with cobalt based alloy trim.</p>
<p>ENERGY EFFICIENT</p> <p>The Velan steam trap wastes no live steam during its operation. This can save a customer hundreds of dollars per trap annually.</p>	<p>NOT ENERGY EFFICIENT</p> <p>The inverted bucket steam trap requires 3 pounds of live steam to cycle. At current energy costs, this is an annual cost of \$ 250.00 per trap.</p>
<p>MODULATED DISCHARGE</p> <p>The Velan steam trap modulates the condensate out of the system continuously. It is understood in industry that valves that modulate last much longer than valves that cycle on-off.</p>	<p>BLAST ON – BLAST OFF DISCHARGE</p> <p>The inverted bucket steam trap discharges condensate by blasting on and off. If the steam trap cycles 2 times per minute, that is over 1,000,000 cycles per year.</p>
<p>INTEGRAL CHECK VALVE</p> <p>The discharge valve in the trap acts as a check valve providing full back flow control.</p>	<p>NO CHECK VALVE AVAILABLE</p> <p>The inverted bucket steam trap cannot prevent back flow. You MUST install a check valve.</p>
<p>NO PLUGGING</p> <p>The valve on the Velan steam trap is in the downstream position. All flashing of condensate occurs after it has passed through the orifice. Copper oxides and Iron oxides will not foul or plug the orifice in the Velan steam trap.</p>	<p>PLUGS DUE TO DIRT AND COPPER OXIDES</p> <p>Condensate must flash through a restricted orifice before it enters the condensate return system. Dirt and copper oxides chemically bond to the inside of the orifice, eventually closing the flow path. This leads to plugging, water-logging, and freezing.</p>
<p>OPERATES FINE IN SUPERHEAT</p> <p>Velan steam traps operate fine when superheat is present.</p>	<p>SUPERHEAT</p> <p>Inverted bucket steam traps do not operate well in superheat environments. The trap boils off the prime and blows live steam.</p>